

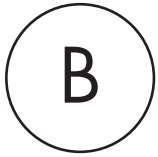

GARDEN 24
INDOOR & OUTDOOR COLLECTION

COLORI - COLORS - FARBEN - COULEURS - COLORES



BIANCO EVOLUTION
 BIANCO ORIGIN



TRASPARENTE



OPALINO



GRIGIO
 



ANTRACITE



CENERE



CIPRIA
 



AVANA

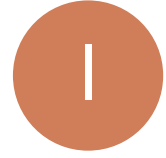

TORTORA

IMPRUNETA



COTTO



ROSSO



RUBINO



CORTEN



LAMPONE



SALVIA



PISTACCHIO



VERDE



VERDE ROSMARINO



GIALLO - NERO

Custom Colours
LINEA EVOLUTION

SCOPRI LA GAMMA COLORI PG. 106
 DISCOVER THE COLORS RANGE PG. 106



RICONOSCIBILE NIR - RICICLABILE
 NIR DETECTABLE - RECYCLABLE
 VEDI - SEE PG. 14-15



RICICLABILE CERTIFICATO CYCLOS
 RECYCLABLE CYCLOS CERTIFIED
 VEDI - SEE PG. 14-15

Legenda - Legend - Zeichenerklärung - Symboles - Símbolos

COD.

CODICE ARTICOLO
 Product code
 Produkt-Kode
 Code produit
 Código del artículo



MISURE UTILI
 Internal sizes
 Innenmaß
 Dimensions interne
 Medidas útiles



CONFEZIONAMENTO
 Packaging
 Verpackung
 Colisage
 Unidades



MISURA
 Size
 Ausmass
 Taille
 Medida



COLORI A MAGAZZINO
 Colors on stock
 Farben auf Lager
 Couleurs en stock
 Colores estándar



INTERNO
 Indoor
 Drinnen
 Pour intérieur
 Interior



MISURE ESTERNE
 External sizes
 Größe
 Dimensions externe
 Medidas externas



SOTTOVASO ADATTO
 Suitable saucer
 Passende Untersetzer
 Soucoupe conseillé
 Platillo adecuado



ESTERNO
 Outdoor
 Draußen
 Pour l'extérieur
 Exterior

we
look
to
the
fu
ture
na



Welcome TO YOUR NEW Garden

UNA COLLEZIONE DI
NUOVI PRODOTTI E COLORI

A COLLECTION OF NEW
COLOURS AND PRODUCTS



NEW COLOUR Quadro Mega



NEW PRODUCT Quadro Arkè



NEW PRODUCT Divo Elegance



NEW PRODUCT Echo 25-30



NEW COLOUR Cassetta Domus



NEW PRODUCT Kit Portavaso Arkè Small



NEW PRODUCT Mini Box



NEW COLOUR Premium



NEW PRODUCT Kit Portavaso Arkè Medium



NEW PRODUCT Display Expo



NEW PRODUCT Cassettone Arkè



NEW COLOUR Cassettone Mega















INDICE PRODOTTI PRODUCTS INDEX















■ INJECTION MOULDING

■ ROTOMOULDING















VASO APPESO - HANGING POT 













TONDI - ROUND

						
NEW					NEW COLORS	NEW COLORS
Decò	Verve Slim Verve Slim Crystal	Verve Verve Crystal	Arkè	Arkè Slim	Premium	Premium
Ø 10 - Ø14	Ø 13	Ø 11 - 13 - 15 - 18 - 20 25 - 30 - 35	Ø 11 - 15 - 16 - 18 - 22 26 - 30 - 36 - 42	Ø 33	Ø 16 - 18 - 20 - 22 25 - 30	Ø 35 - 40 - 45 - 50 60 - 80
						
pg. 35	pg. 63 - 64	pg. 58 - 61	pg. 42	pg. 46	pg. 74	pg. 74















						
		NEW				
Zeus Matt	Rhea Elegance	Echo	Ares	Hera	Hera Elegance	Chiron
Ø 30 - 40 - 50 - 60	Ø 30 - 40	Ø 25 - 30 - 35	Ø 20 - 30 - 40	Ø 30 - 40 - 50 - 60	Ø 30 - 40 - 50	Ø 50 - 60
						
pg. 125	pg. 115	pg. 130	pg. 123	pg. 119	pg. 117	pg. 126

CIOTOLE - BOWLS



						
					NEW	
Firenze Assemblata	Rumba Assemblata	Verve Ciotola	Ciotolone	Thetis Elegance	Thetis	Athena
Ø 18 - 20 - 22 - 25 30 - 35 - 40	Ø 18 - 20 - 22 - 25 30 - 35 - 40	Ø 30	Ø 30 - 40 - 50 - 60	Ø 30 - 40	Ø 30 - 40 - 50 - 60	50
						
pg. 84	pg. 80	pg. 67	pg. 82	pg. 135	pg. 137	pg. 138

					
					NEW
Themis Quadro	Millerighe Quadro	Logos Matt	Eros	Geryon	Divo Elegance
40	40	30 - 40	30 - 38	40	30
					
pg. 177	pg. 183	pg. 170	pg. 173	pg. 174	pg. 149

QUADRI ALTI
HIGH SQUARE PLANTERS

						
Kit Premium	Kit Premium Wall	Conca Pure	Conca Style	Doppio Bordo Liscio	Doppio Bordo Festonato	Hermes Elegance
Ø 20	Ø 20	Ø 38	Ø 38	Ø 35 - 45 - 55 - 75	Ø 30 - 40 - 50 - 60	Ø 30 - 40
						
pg. 77	pg. 77	pg. 40	pg. 39	pg. 128	pg. 129	pg. 120

TONDI ALTI - HIGH ROUNDS

				
Tylus Matt	Tylus Elegance	Style	Talos Matt	Talos Elegance
Ø 23 - 30 - 40	Ø 30	Ø 36 - 38	Ø 33 - 43	Ø 33
				
pg. 113	pg. 112	pg. 37	pg. 111	pg. 109

QUADRI - SQUARE

						
Verve Quadro	Quadro Mega	Arkè Quadro	Minos	Modus Quadro	Momus	Quadro Elegance
11 - 13 - 15 - 20	20 - 25 - 30 - 40 - 45	40	25 - 40 - 60	40	35 - 50	30 - 40
						
pg. 68	pg. 88	pg. 52	pg. 166	pg. 158	pg. 164	pg. 152

CASSETTE WINDOW BOX PLANTERS

						
Balconcino Assemblata	Verve Cassetta	Cassetta Domus	Cassetta Primavera	Kit Primavera	Cassetta Patio	Arkè Cassetta
20 - 30 - 40	30 - 40 - 45	40 - 50 - 60 - 80	40 - 50 - 60	40 - 50 - 60	45 - 55	40 - 50
						
pg. 100	pg. 70	pg. 92	pg. 97	pg. 98	pg. 94	pg. 51

INDICE PRODOTTI PRODUCTS INDEX

INJECTION MOULDING

ROTOMOULDING

VASO APPESO - HANGING POT



Arkè Balcony	Minos Cassetta	Mysia	Calypso Matt	Iris
25 - 40	45	40 - 50	50	60
pg. 48	pg. 167	pg. 146	pg. 145	pg. 140



ALTRE FORME
OTHER SHAPES

Themis Angolare	Themis Sottovaso Angolare	Themis Parete	Themis Sottovaso Parete	Etichetta	Mini Box	Display Expo
40	40	40	40	-	Cassetta Domus Cassetta Primavera Kit Primavera Balconiera Domus fissa	Arkè - Premium - Sott. Domus
pg. 178	pg. 178	pg. 179	pg. 179	pg. 185	pg. 188	pg. 186

SUPPORTI IN METALLO
METAL HOLDERS

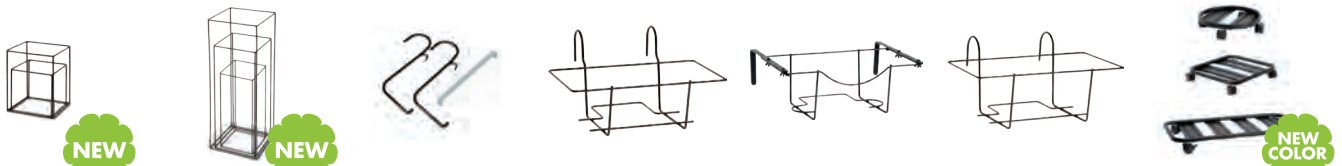

Kit Portavaso Arkè Small	Kit Portavaso Arkè Medium	Kit Supporti Primavera	Balconiera Domus Fissa	Balconiera Domus Regolabile	Balconiera Patio Fissa	Carrello
14 - 15,5	17 - 21 - 24	-	40 - 50 - 60	40 - 50 - 60	45 - 55	-
pg. 45	pg. 45	pg. 101	pg. 101	pg. 101	pg. 101	pg. 185

CARATTERISTICHE
FEATURES - MERKMALE
CARACTÉRISTIQUES - CARACTERÍSTICAS



FINITURA A MANO
Hand finished - Handfertigung
Terminé à main - Acabado a mano



RESISTENZA ALLE TEMPERATURE
Temperature resistance - Temperatuurbestendigheid
Résistance aux températures - Resistencia a la temperatura



PER USO INTERNO ED ESTERNO
For indoor and outdoor use - Für Haus und Garten
Pour intérieur et extérieur - Para interior y jardín



RESISTENTI AI RAGGI UV
UV resistant - UV beständig
Résistant aux UV - Resistente a los UV



LEGGERI E MANEGGEVOLI
Lightweight and easy to handle - Leicht und einfach zu bewegen
Légers et faciles de manier - Lígero y fácil de mover

CASSETTONI
LARGE PLANTERS

NEW	NEW COLORS					
Arkè Cassettone	Cassettone Mega	Millerighe Cassetta	Themis Cassetta	Modus Cassetta	Cassettone Elegance	Separè Elegance
80	60 - 80 - 100	60 - 80 - 100	80 - 100	80	60 - 80	80
pg. 54	pg. 90	pg. 183	pg. 176	pg. 160	pg. 154	pg. 151

VASI APPESI
HANGING POTS

Arkè Balcony	Kit Primavera	Clio	Kit Premium	Kit Premium Wall	Basket Siena Assemblato
25 - 40	40 - 50 - 60	32	Ø 20	Ø 20	Ø 14 - 16 - 18 - 20 22 - 25
pg. 48	pg. 98	pg. 143	pg. 77	pg. 77	pg. 86

SOTTOVASI - SAUCERS

NEW COLORS	NEW COLORS	NEW COLORS		NEW COLORS	NEW COLORS	
Sottovaso Domus	Atlas Sottovaso	Sottovaso Quadro Mega	Themis Sottovaso Quadro	Sottocassetta Domus	Sottocassetta Mega	Themis Sottocassetta
Ø 10 <-> 74	Ø 26 - 30 - 32 - 36 - 42 48 - 52 - 58	20 - 25 - 30 - 40 - 45	40	40 - 50 - 60 - 80	60 - 80 - 100	60 - 80 - 100
pg. 79	pg. 133	pg. 89	pg. 133 - 177	pg. 93	pg. 91	pg. 133 - 176



RESISTENTI AGLI URTI
Shock resistant - Stoßfest
Résistants aux chocs - Resistente a los golpes



IMPILABILI
Stackable - Stapelbar
Apilable - Apilables



NON VERNICIATI
Not painted - Nicht lackiert
Non laqués - No pintura



RIDUCE LA PROLIFERAZIONE DELLE ZANZARE
It reduces the proliferation of mosquitoes
Il réduit la prolifération des moustiques
Es reduziert die wuchern von Mücken
Reduce the proliferacion de mosquitos



PROGETTATI E PRODOTTI IN ITALIA
Designed and manufactured in Italy
Entworfen und hergestellt in Italien
Conçu et produit en Italie
Diseñado y fabricado en italia



100% MATERIALI ATOSSICI E RICICLABILI
100% non toxic and recyclable materials
100% atoxische und wiederverwertbare Materialien
100% matériaux non-toxiques et recyclables
100% materiales non-toxicos y reciclables

A

Ares	pg. 123
Arkè	pg. 42
Arkè Balcony	pg. 48
Arkè Cassetta	pg. 51
Arkè Cassettone	pg. 54
Arkè Quadro	pg. 52
Arkè Slim	pg. 46
Athena	pg. 138
Atlas Sottovaso	pg. 133

B

Balconcino Assemblata	pg. 100
Balconiere Fissa + Reg.	pg. 101
Basket Siena Assemblato	pg. 86

C

Calypso Matt	pg. 145
Carrello Quadrato	pg. 185
Carrello Rotondo	pg. 185
Carrello Rettangolare	pg. 185
Cassetta Domus + Sott.	pg. 92
Cassetta Patio	pg. 94
Cassetta Primavera	pg. 97
Cassettone Elegance	pg. 154
Cassettone Mega + Sott.	pg. 90
Chiron	pg. 126
Ciotolone	pg. 82
Clio	pg. 143
Conca Pure	pg. 40
Conca Style	pg. 39

D

Decò	pg. 35
Display Expo	pg. 186
Divo Elegance	pg. 149
Doppio Bordo Liscio	pg. 128
Doppio Bordo Festonato	pg. 129

E

Echo	pg. 130
Eros	pg. 173
Etichetta	pg. 185

F

Firenze Assemblata	pg. 84
--------------------	--------

G

Geryon	pg. 174
--------	---------

H

Hera	pg. 119
Hera Elegance	pg. 117
Hermes Elegance	pg. 120

I

Iris	pg. 140
------	---------

K

Kit Portavaso Arkè S/M	pg. 45
Kit Primavera	pg. 98
Kit Premium + Wall	pg. 77
Kit Supporti Primavera	pg. 101

L

Logos Matt	pg. 170
------------	---------

M

Millerighe Cass. + Sott.	pg. 183
Millerighe Quad. + Sott.	pg. 183
Mini Box	pg. 188
Minos	pg. 166
Minos Cassetta	pg. 167
Modus Cassetta	pg. 160
Modus Quadro	pg. 158
Momus	pg. 164
Mysia	pg. 146

P

Premium	pg. 74
---------	--------

Q

Quadro Elegance	pg. 152
Quadro Mega + Sott.	pg. 88

R

Rhea Elegance	pg. 115
Rumba Assemblata	pg. 80

S

Separè Elegance	pg. 151
Sottovaso Domus	pg. 79
Style	pg. 37

T

Talos Elegance	pg. 109
Talos Matt	pg. 111
Themis Angolare + Sott.	pg. 178
Themis Cassetta + Sott.	pg. 176
Themis Parete + Sott.	pg. 179
Themis Quadro + Sott.	pg. 177
Thetis	pg. 137
Thetis Elegance	pg. 135
Tylus Elegance	pg. 112
Tylus Matt	pg. 113

V

Verve	pg. 58
Verve Cassetta	pg. 70
Verve Ciotola	pg. 67
Verve Crystal	pg. 61
Verve Quadro	pg. 68
Verve Slim	pg. 63
Verve Slim Crystal	pg. 64

Z

Zeus Matt	pg. 125
-----------	---------

pg. **32****originDECOR**

P.P Injection moulding

Arkè	pg. 42	Conca Pure	pg. 40	Verve Cassetta	pg. 70
Arkè Balcony	pg. 48	Conca Style	pg. 39	Verve Ciotola	pg. 67
Arkè Cassetta	pg. 51	Decò	pg. 35	Verve Crystal	pg. 61
Arkè Cassettone	pg. 54	Kit Portavaso Arkè S/M	pg. 45	Verve Quadro	pg. 68
Arkè Quadro	pg. 52	Style	pg. 37	Verve Slim	pg. 63
Arkè Slim	pg. 46	Verve	pg. 58	Verve Slim Crystal	pg. 64

pg. **72****originESSENTIAL**

P.P Injection moulding

Balconcino Assemblata	pg. 100	Cassetta Patio	pg. 94	Kit Primavera	pg. 98
Balconiere Abbinabili	pg. 101	Cassettone Mega + Sottoc.	pg. 90	Kit Supporti Primavera	pg. 101
Balconiera Fissa + Reg.	pg. 92	Cassetta Primavera	pg. 97	Premium	pg. 74
Balconiera Patio Fissa	pg. 94	Ciotolone	pg. 82	Quadro Mega + Sott.	pg. 88
Basket Siena	pg. 86	Firenze Assemblata	pg. 84	Rumba Assemblata	pg. 80
Cassetta Domus + Sottoc.	pg. 92	Kit Premium + Wall	pg. 77	Sottovaso Domus	pg. 79

pg. **102****evolution ELEGANCE & MATT**

L.L.D.P.E. Rotational moulding

Ares	pg. 123	Hera Elegance	pg. 117	Separè Elegance	pg. 151
Athens	pg. 138	Hermes Elegance	pg. 120	Talos Elegance	pg. 109
Atlas - Themis Sottovaso	pg. 133	Iris	pg. 140	Talos Matt	pg. 111
Calypso Matt	pg. 145	Logos Matt	pg. 170	Themis Angolare + Sottoc.	pg. 178
Cassettone Elegance	pg. 154	Millerighe Cass. + Sottoc.	pg. 183	Themis Cassetta + Sottoc.	pg. 176
Chiron	pg. 126	Millerighe Quad. + Sottoc.	pg. 183	Themis Parete + Sottoc.	pg. 179
Clio	pg. 143	Minos	pg. 166	Themis Quadro + Sottoc.	pg. 177
Divo Elegance	pg. 149	Minos Cassetta	pg. 167	Thetis	pg. 137
Doppio Bordo Liscio	pg. 128	Momus	pg. 164	Thetis Elegance	pg. 135
Doppio Bordo Festonato	pg. 129	Modus Quadro	pg. 158	Tylus Elegance	pg. 112
Echo	pg. 130	Modus Cassetta	pg. 160	Tylus Matt	pg. 113
Eros	pg. 173	Mysia	pg. 146	Zeus Matt	pg. 125
Geryon	pg. 174	Quadro Elegance	pg. 152		
Hera	pg. 119	Rhea Elegance	pg. 115		

pg. **184****Accessori**

Accessories - Zubehöre - Accessoires - Accesorios

Carrello Quadrato	pg. 185	Carrello Rettangolare	pg. 185
Carrello Rotondo	pg. 185	Etichetta	pg. 185

pg. **186****Info & Visual merchandising**

2

FATTO CON ENERGIA RINNOVABILE AL 100% E MACCHINARI A BASSO CONSUMO.

MADE WITH 100% RENEWABLE ENERGY AND ENERGY-EFFICIENT MACHINES.

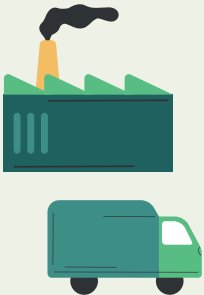

MATERIE PRIME RIGENERATE CERTIFICATE.

CERTIFIED REGENERATED RAW MATERIALS.



EuCertPlast

3

IMBALLAGGI FATTI IN MATERIALE RICICLATO E RICICLABILE AL 100%.

PACKAGING MADE WITH 100% RECYCLED AND RECYCLABLE MATERIAL.



FATTO CON PLASTICA RICICLATA E RICICLABILE.

MADE WITH RECYCLED AND RECYCLABLE PLASTIC.



4



1



**PERCHÈ
ACQUISTARE
NICOLI**



**RENDE
FELICI?**



CI FA SENTIRE PARTE DELLA SOLUZIONE PERCHÉ È FATTO DI PLASTICA RICICLATA DA POST CONSUMO E POST INDUSTRIALE.
IT DOES NOT WASTE RESOURCES BECAUSE IT IS MADE FROM POST CONSUMER AND POST-INDUSTRIAL RECYCLED PLASTIC.

È ECOLOGICO PERCHÉ NON SPRECA RISORSE ED È RICICLABILE AL 100%.
IT'S "GREEN" BECAUSE 100% RECYCLABLE.

AMA LE PIANTE, È BELLO, SICURO ED ESENTE DA METALLI PESANTI.
IT LOVES PLANTS, IT'S BEAUTIFUL, SAFE AND FREE OF HEAVY METALS.

È PRODOTTO SENZA EMETTERE NELL'ATMOSFERA NÉ CO₂ NÉ POLVERI SOTTILI.
IT'S PRODUCED WITHOUT ANY CO₂ OR FINE DUST RELEASE INTO THE ATMOSPHERE.



**WHY
BUYING
NICOLI**  **MAKE YOU
HAPPY?**



PER L'AMBIENTE NON BADIAMO A SPESE

Promuoviamo l'**ECONOMIA CIRCOLARE** attraverso il riciclo della plastica da raccolta differenziata e da scarto industriale. E' una scelta ecosostenibile anche se aumenta i costi di produzione.

PCR PLASTICA RICICLATA DA RACCOLTA DIFFERENZIATA

POST-CONSUMER RECYCLED PLASTIC

Questa è plastica derivata da prodotti di uso quotidiano, trasformati in qualcosa di nuovo.

Non è facile riciclare la plastica post-consumo; vi sono implicazioni economiche: la raccolta **1**, la pulizia e la selezione **2**, la rielaborazione e distribuzione **3-4**, la trasformazione **5**, nonché problemi fisici quali irregolarità nel colore e nella qualità oppure la contaminazione con altri materiali.

I prodotti realizzati in plastica post-consumo chiudono il circuito, deviando i prodotti in plastica dalla discarica e consentendo invece di trasformarli in qualcos'altro.

This is plastic derived from everyday products, transformed into something new.

Post-consumer plastic is not easy to recycle; there are economic implications such as collection **1**, cleaning and selection **2**, reworking and distribution **3-4**, transformation **5**, as well as physical problems such as color and quality irregularities or contamination with other materials.

Products made of post-consumer plastic close the circuit, diverting plastic products from the waste dump allowing them to be transformed into something else.

La plastica certificata che noi utilizziamo è una garanzia per chi sceglie i nostri prodotti.



EuCertPlast



WE SPARE NO EXPENSE WHEN TALKING ABOUT THE ENVIRONMENT

Nicoli promotes the **CIRCULAR ECONOMY** through the recycling of plastic both from post-consumer and post-industrial. It's an eco-sustainable choice even if it increases production costs.

PIR

PLASTICA RICICLATA DA SCARTO INDUSTRIALE

POST-INDUSTRIAL RECYCLED PLASTIC

Questa è plastica che è stata raccolta nel nostro e in altri stabilimenti di stampaggio della plastica e che normalmente viene gettata via come scarto di produzione o cambio colore.

Il materiale viene raccolto **1** e direttamente rielaborato e distribuito **2-3** per la sua trasformazione **4** in qualcos'altro.

Alcuni stampi producono inevitabilmente scarti e, in alcuni casi, ciò avviene su larga scala. Con questo tipo di riciclaggio vi è un grande controllo sul tipo di materiale, sulla consistenza e sulla qualità.

This is plastic that has been collected in the plastic molding plant and which is normally thrown away like production waste or color changes.

The material is collected **1** and directly re-processed and distributed **2-3** for its transformation **4** into something else.

Some molds inevitably produce waste and, in some cases, this happens on a large scale. With this type of recycling there is great control over the type of material, consistency and quality.

The certified plastic we use is a guarantee for those who choose our products.



EuCertPlast

Vasi Riciclabili al 100%.



La maggior parte dei nostri vasi **colorati** hanno già ottenuto la certificazione di leggibilità **NIR** (near infrared waves).

Gli impianti di trattamento dei rifiuti, attraverso i separatori ottici, riconoscono correttamente il materiale con cui sono stati prodotti i nostri vasi, rimettendolo nel ciclo produttivo per dare origine a nuovi oggetti in plastica di qualità.

I nostri vasi **neri** sono sempre **riciclabili al 100%**.

Le aziende di riciclaggio non sempre li separano correttamente, di conseguenza il materiale nero viene spesso riutilizzato per dare origine a nuovi oggetti di qualità inferiore.

Tutti i nostri prodotti sono **100% Riciclabili** e alimentano l'economia circolare.



Molti dei nostri prodotti hanno già ottenuto dall'istituto CYCLOS-HTP il certificato di riciclabilità al 100% in quanto realizzati senza utilizzo di metalli pesanti e con un contenuto di Carbon Black prossimo o uguale a ZERO.

Consulta la gamma colori per conoscere quelli certificati.

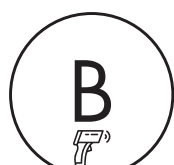

BIANCO



OPALINO



GRIGIO



CIPRIA



TORTORA



COTTO

100% Recyclable flowerpots.



Most of our **colored** flowerpots have already obtained **NIR** (near infrared waves) detectable certification.

The waste treatment plants, through optical separators, correctly recognize the material with which our pots were produced, putting it back into the production cycle to give rise to new quality plastic objects.

Our **black** pots are always **100% recyclable**.

Recycling companies don't always separate them properly, so the black material is often reused to give rise to new but lower quality items.

All of our products are **100% Recyclable**, so they simply close the loop.



Many of our products have already obtained from the CYCLOS-HTP institute the 100% recyclability certificate as they are manufactured without the use of heavy metals and with a carbon black content close or equal to ZERO.

Verify the colours palette to know the certified ones.



RICICLABILE? RECYCLABLE?

Lo sapevi che molti materiali utilizzati per produrre vasi e fioriere sono difficilmente o per nulla riciclabili? Tu da che parte stai?

Did you know that many materials used to manufacture planters are hardly or not at all recyclable? Which side are you on?

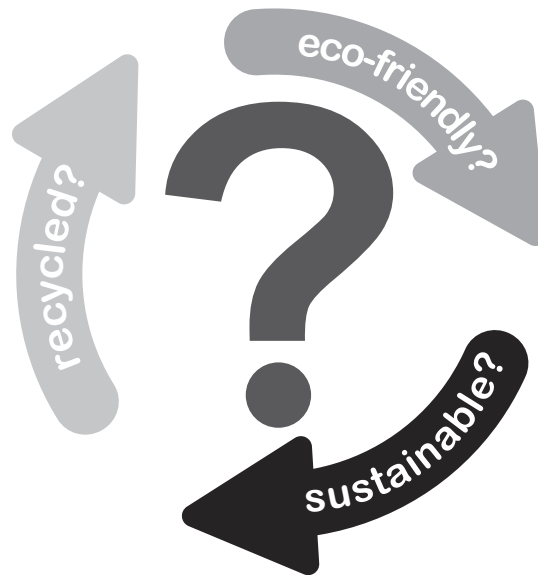

**BIOPLASTIC
FIBERCLAY
POLYRESIN
CERAMIC**



RICICLATO! RECYCLED!

Riciclato e Riciclabile!
Ecologico e Sostenibile!
Zero emissioni CO₂!
Scelgo 2Second life!

Recycled & Recyclable!
Eco-friendly & Sustainable!
Zero CO₂ emissions!
I choose 2Second Life!



2Second life

THE PLASTIC'S SECOND TIME



Fatto con plastica riciclata.



I prodotti **2Second life** (seconda vita) di Nicoli sono realizzati con polipropilene riciclato, raccolto sia da scarti industriali post-processo (PIR) che post-consumo (PCR) da raccolta differenziata, riutilizzati e combinati con la tecnologia più avanzata per creare prodotti di pregio di uso quotidiano.

I prodotti che contengono plastica **2Second life** sono una soluzione efficace per contrastare l'inquinamento plastico, l'inquinamento atmosferico, l'inquinamento idrico e la scarsità di risorse.

**Vuoi anche tu fare parte della soluzione?
Unisciti a noi e usa prodotti 2Second life!**

CIFRE E FATTI

Secondo diversi studi, riciclare una tonnellata di rifiuti di plastica:

Impedisce a 1.5 t di gas serra di contribuire al cambiamento climatico.

Prevent 1.5 ton of greenhouses gasses from contributing to climate change.

Consente di risparmiare fino a 16,3 barili di petrolio.

Saves as much as 16.3 barrels of oil.

FACTS & FIGURES

According to several studies, recycling a ton of plastic waste:

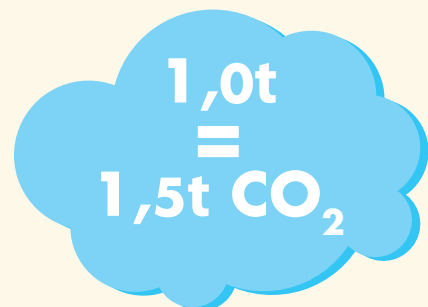

16,3



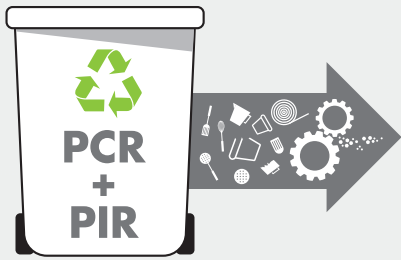

**Fatto con plastica riciclata.
Made with recycled plastic.**



Made with recycled plastic.



Nicoli's **2Second life** products are made with recycled polypropilene collected both from industrial post-process (PIR) waste and post-consumer (PCR) from separate collection of household waste, re-used and combined with the most advanced technology to create fine products of daily use.

Products with **2Second life** plastic inside are an effective solution to counteract plastic pollution, air pollution, water pollution and resource scarcity.

**Do you want to be part of the changing?
Join us and start using 2Second life products!**

CIFRE E FATTI

Secondo diversi studi, riciclare una tonnellata di rifiuti di plastica:

Consente di risparmiare 5.774 Kwh di energia, pari al consumo di 2 abitazioni da 4 persone.

Saves 5.774 kWh energy equal to TWO 4 people houses.

Genera ricavi per tutta la filiera e vantaggi sociali maggiori rispetto al costo dello smaltimento in discarica.

It generates revenues for the entire supply chain and social benefits greater than the cost of landfilling.

FACTS & FIGURES

According to several studies, recycling a ton of plastic waste:

5.774 Kwh

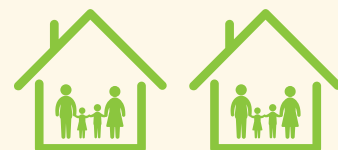

ABBIAMO SCELTO DI FAR PARTE DELLA SOLUZIONE! NON DEL PROBLEMA.

2Secondlife

PCR POST-CONSUMER

PIR POST-INDUSTRIAL

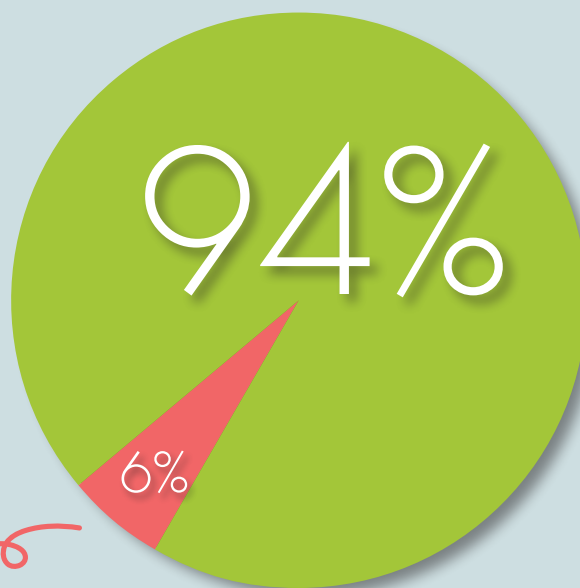

VIRGIN RAW MATERIAL

94%

Utilizziamo il 94% di plastica riciclata.



Forti della nostra esperienza nel settore florovivaistico dove da anni si utilizza materia prima riciclata, abbiamo deciso che anche la produzione di vasi e fioriere garden di oggi deve avvenire utilizzando il più possibile plastica riciclata.

Ci sentiamo tutti responsabili del mondo in cui viviamo per questo Nicoli crede fermamente nel ciclo economico del riutilizzo della materia prima. Utilizzando quanto è stato già prodotto finora senza richiedere nuova produzione di materia prima riduciamo fortemente il consumo di risorse e di energia necessaria per produrla, quindi minor impatto ambientale.



WE CHOOSE TO BE PART OF
THE SOLUTION!
NOT PART OF THE PROBLEM.

94%

**We use 94%
of recycled plastic.**



Strengthened by our experience in the horticultural sector where we have been using recycled raw materials for years, we have decided that even the production of today's garden pots and planters must take place using as much recycled plastic as possible.

We all feel responsible for the world we live in, that's why Nicoli strongly believe in the economic cycle of raw material reuse.

By using what has already been produced so far without requiring new production of raw materials, we greatly reduce the consumption of resources and energy needed to produce it, therefore lower environmental impact.

2^{da} *Seco* *na* life

PCR POST-CONSUMER
PIR POST-INDUSTRIAL

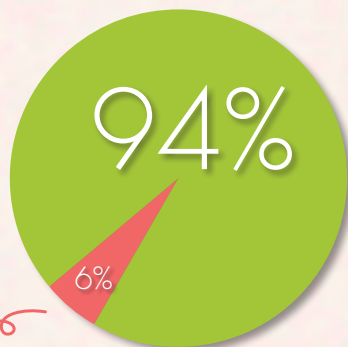

VIRGIN RAW
MATERIAL

6%

Solo il 6% di plastica vergine utilizzata.

La plastica di per sè non è inquinante durante il suo ciclo di vita, anzi è un materiale altamente sostenibile in quanto la sua produzione richiede meno energia di quanta ne occorre per il vetro o la carta o il legno, ed è riciclabile infinitamente al 100%.

Un oggetto in plastica raggiunta la fine del suo ciclo di vita diventa una risorsa importante attraverso la raccolta differenziata e dà vita ad un altro oggetto con pari caratteristiche.

La plastica non è un nemico da combattere ma bensì un amico da valorizzare dopo che ci ha aiutato a vivere meglio!

Benvenuta plastica!

100%

Sostenibile.

Il riciclo della plastica necessita di minori quantità di energia rispetto alla produzione della materia prima vergine derivata dal petrolio.

Meno energia, meno inquinamento!

La plastica rende il nostro Mondo più sostenibile.



6%

Only 6% of virgin plastic used in our production processes.

The plastic itself is not polluting during its use, indeed it is a highly sustainable material as its production requires less energy than it takes for glass or paper or wood and it is 100% infinitely recyclable. At the end of his life cycle a plastic item becomes an important resource through separate collection and gives life to another item with equal characteristics.

Plastic is not an enemy to fight but rather a friend to be valued after it has helped us living better!

Welcome plastic!

100%

Sustainable.

The recycling of plastic requires less energy than the production of virgin raw material from oil.

Less energy, less pollution!

Plastic makes our World more sustainable.

BIOPLASTICA? NON ANCORA GRAZIE.

BIOPLASTIC? NOT YET THANKS.



Il nostro impegno con l'ambiente ci impone di esplorare costantemente nuove strade per realizzare prodotti sostenibili e amici dell'ambiente ma crediamo che per il momento la BIOPLASTICA per produrre vasi e fioriere non sia la soluzione.

Ci sono ancora troppe incognite riguardo la sostenibilità della sua produzione il suo corretto smaltimento a fine vita mentre conosciamo bene la sostenibilità della plastica riciclata che utilizziamo.

Our commitment to the environment requires us to constantly explore new ways to make sustainable and environmentally friendly products but we believe that BIOPLASTIC to produce pots and planters is not the solution for the moment.

There are still too many unknowns regarding the sustainability of its production and its proper disposal at the end of its life while we know well the sustainability of the recycled plastic we use.

Il riciclaggio della plastica è la chiave per migliorare l'efficienza delle risorse e ottenere importanti benefici ambientali.



Sapevi che molti prodotti in BIOPLASTICA necessitano di un riciclo dedicato?

Did you know that many products made of BIOPLASTIC require dedicated recycling?



ORGANIC



PLASTIC



**RESIDUAL
WASTE**

Se ti sei accorto di averne acquistati e adesso devi smaltirli, verifica presso il tuo servizio di raccolta rifiuti in quale contenitore è meglio conferirli.

Non sorprenderti se in alcuni casi ti diranno che i prodotti in bioplastica non possono essere riciclati.

If you noticed that you purchased any and now you have to dispose of them, first check with your waste collector services which container is better to use.

Don't be surprised or upset whether someone will tell you that they cannot be recycled.

Plastic recycling is the key to improve the resource efficiency and achieve important environmental benefits.



Siamo un'azienda
Verde con la **V**
Maiuscola!

We are a **Green**
company with
a capital **G**.



100%

ENERGIA ELETTRICA DA FONTI RINNOVABILI.

Ci impegnamo a produrre i nostri vasi con quanta più energia rinnovabile possibile, utilizzando sia energia elettrica autoprodotta di origine fotovoltaica sia attingendo da partner certificati energia elettrica di origine eolica e idroelettrica.

Queste scelte generano dei costi di produzione maggiori ma vogliamo dare il nostro contributo per consegnare alle future generazioni un pianeta migliore.

La sola componente di energia autoprodotta equivale a 93.6 ton annue di CO₂ non rilasciate nell'atmosfera contribuendo così a ridurre il riscaldamento globale.

Scegliendo i prodotti Nicoli condividi i nostri obiettivi.



100%

ELECTRICITY FROM RENEWABLE SOURCES.

We constantly strive to make our production more and more sustainable using renewable energy as much as possible. Electricity used is coming from different renewable sources: Solar power is self-produced by our photovoltaic system, wind power is sourced from certified partners as the hydroelectric power.

This is a more costly production process but we want to make our contribution to deliver a better planet to future generations.

The self-produced energy component alone is equivalent to 93.6 tons of CO₂ not released into the atmosphere, thus helping to reduce global warming.

Choosing Nicoli products you agree with our target!

100%

IMBALLI ECOLOGICI.

Gli imballi che usiamo sono sacchetti di plastica riciclata, scatole con carta riciclata e pallets riutilizzabili. Tutte le etichette applicate ai prodotti, sono riciclabili con il prodotto stesso.

100%

ECO-FRIENDLY PACKAGING.

The packagings we use are recycled plastic bags, recycled paper boxes and reusable wood pallets. All labels applied are recyclable with the products itselfs.

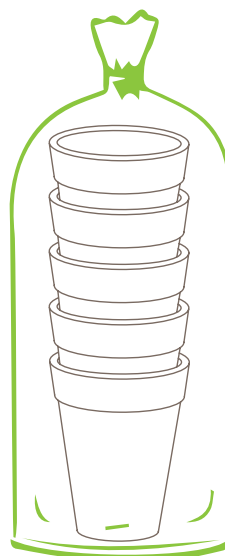
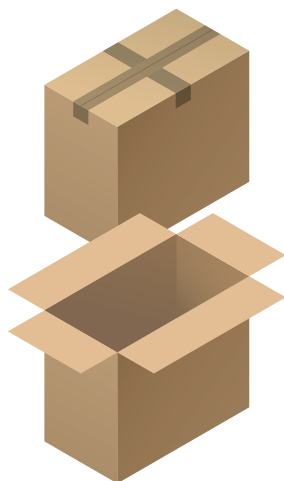



SIAMO UN PARTNER AFFIDABILE SEMPRE AL PASSO CON I TEMPI!



Siamo sempre attenti all'evoluzione del mercato inserendo ogni anno nuovi prodotti e aggiornando il nostro assortimento colori. Con noi potete contare su una vasta gamma di vasi e fioriere in colori sempre nuovi e di tendenza che sapranno sedurre i vostri clienti.

We take always care to market development adding new products every year and updating our color assortment. With us you can count on a wide range of planters in new and trendy colors that will seduce your customers.

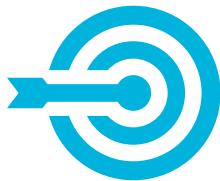

Il nostro obiettivo è fornire un servizio accurato e puntuale. La nostra struttura produttiva ci permette di produrre più di 90 milioni di vasi e fioriere ogni anno, una cifra davvero importante! Nonostante tutto ci impegnamo ad avere tutte le referenze a catalogo sempre disponibili per poter consegnare gli ordini nel minor tempo possibile perchè possiate soddisfare al meglio i vostri clienti.

We constantly invest to provide an accurate and timely service. Our production facility allows us to produce more than 90 million vases and planters every year, a very relevant number!. We are committed to having all the references show in our catalog always available for quick deliveries so that you can better satisfy your customers.



WE ARE A RELIABLE PARTNER ALWAYS IN STEP WITH THE TIMES!



Continuiamo ad investire in nuove tecnologie e macchinari all'avanguardia per rispondere alle nuove sfide del mercato e ridurre al minimo l'impatto ambientale.

We continue to invest in new technologies and cutting-edge machinery to respond to new market challenges and minimize environmental footprint.



Più di 2000 punti vendita nel mondo propongono con successo i nostri prodotti.

More than 2000 stores worldwide offer our products successfully.



Da sempre, la nostra operatività produttiva è tutta in Italia. Siamo orgogliosi delle nostre radici e crediamo nel futuro del nostro Paese. Ci sentiamo responsabili e diamo il nostro contributo alla crescita del territorio.

Since the beginning our production activity is completely in Italy. We are proud of our roots and we believe in the future of our Country. We feel responsible and we give our contribution to the growth of the territory.



ORIGIN DECOR

collection



Una gamma di prodotti leggeri e resistenti realizzati in polipropilene riciclato e dedicati alla decorazione. Forme progettate per abbinare estetica e praticità, con colori moderni e accorgimenti tratti dal mondo del florovivaismo. Realizzati con materiali amici dell'ambiente riciclabili al 100%.

A range of lightweight and resistant products made using 100% recycled and recyclable polipropylene. The shapes are designed to combine aesthetic with functionality, the colors are modern. Made using environmentally-friendly materials.

Eine Auswahl von leichten und starken Produkten aus recyceltem Polypropylen hergestellt. Die Produkte verbinden Ästhetik und Funktionalität, moderne Farben und Erfahrung aus der grüne Welt. Hergestellt aus 100% wiederverwertbaren Materialien.

Une gamme de produits légers et résistants, fabriqués en polipropilene recyclé. Formes conçues pour combiner esthétique et praticité avec des couleurs modernes et d'astuces qui viennent du monde de l'horticulture. Fabriqués avec des matériaux respectueux de l'environnement.

Una gama de productos ligeros y resistentes, fabricados en polipropileno reciclado. Formas diseñadas para combinar estética y practicidad, con colores modernos y con la experiencia del mundo de la floricultura. Hechos con materiales ecológicos 100% reciclables.





Set di vasi con riserva d'acqua.

Self watering planter pot set
Selbstbewässernder Pflanztopf Satz
Ensemble de pots de fleurs avec réserve d'eau
Juego de maceteros con reserva de agua



CONFIGURAZIONI - CONFIGURATIONS

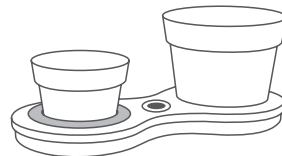
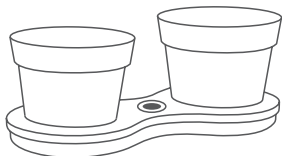

Decò



COD.



7402

10/14

34 x 15 x 13 h.

BGRG



2 X



Ø 10 cm

2 X



Ø 14 cm → 10 cm

2 X



Ø 14 cm

1 X



34 x 15 cm



GARDEN STYLE
ORIGIN DECOR

NEW PRODUCT

COD.



7414

14/14

34 x 15 x 13 h.

BGRG



2 X



Ø 14 cm

1 X



34 x 15 cm



Kit Decò
Decò Kit

Vaso (non incluso)
Pot (not included)

Terriccio (non incluso)
Soil (not included)

Riserva d'acqua 2 cm
Water reserve 2 cm

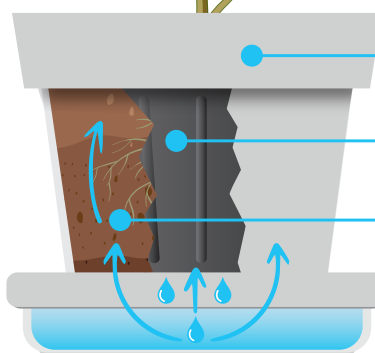



Art. 3636 - 3638

Col. B

 Agave

Opaco - Matt

Style

COD.	1 2 3	cm.	cm.	P	T	B	GRG	CP	SA
3636	36	35,8 x 70 h.	31 x 23,5 h.	●	●	○	○	○	○
3638	38	38,2 x 85 h.	32,9 x 23,5 h.	●	●	○	○	○	○

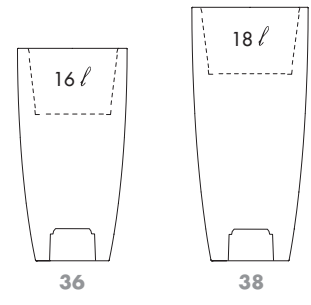

Terriccio
Potting soil
Blumenerde
Terreau
Substrato

2/3

Argilla espansa
Expanded clay
Blähton
Argile expansée
Arcilla expandida

MAX 15 KG

Vaso completo di contenitore
Pot with container
Topf mit Pflanzeinsatz
Maceta con contenedor
Pot avec bac intégré

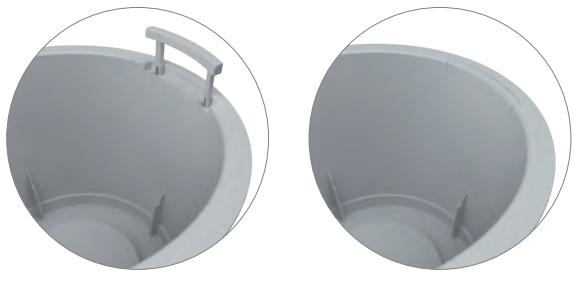

Contenitore estraibile
con maniglie a scomparsa totale

Removable container
with fully retractable handles

Abnehmbarer Pflanzeinsatz
mit vollständig versenkbaren Griffen

Conteneur amovible
avec poignées totalement rétractables

Contenedor extraible
con asas totalmente retráctiles

Contiene perfettamente
Designed to contain
Enthält
Conçu pour contenir
Diseñado para contener

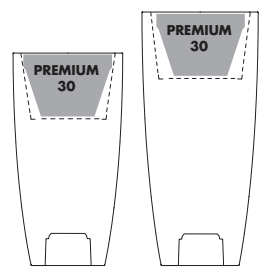

GARDEN STYLE
ORIGIN DECOR



Art. 6238
Col. GRG
Ficus Elastica
IN OUT
Opaco - Matt

Conca Style



COD.

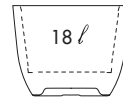

38

6238

38

38,2 x 30 h.

32,9 x 23,5 h.

P

T

B

GRG

CP

SA



Nico's tips



Terriccio
Potting soil
Blumenerde
Terreau
Substrato

2/3

1/3

Argilla espansa
Expanded clay
Blähton
Argile expansée
Arcilla expandida

MAX 15 KG

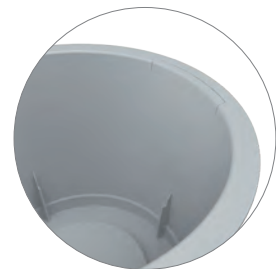

Contenitore estraibile
con maniglie a scomparsa totale

Removable container
with fully retractable handles

Abnehmbarer Pflanzeinsatz
mit vollständig versenkbaren Griffen

Conteneur amovible
avec poignées totalement rétractables

Contenedor extraible
con asas totalmente retráctiles

Vaso completo di contenitore
Pot with container
Topf mit Pflanzeinsatz
Maceta con contenedor
Pot avec bac intégré

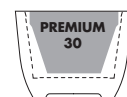

Contiene perfettamente
Designed to contain
Enthält
Conçu pour contenir
Diseñado para contener



GARDEN STYLE
ORIGIN DECOR

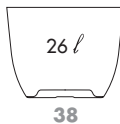

Conca Pure

	COD.						
PCS	7638	38	38,2 x 30 h.	4335			





Art.	7638
Col.	B - CP
	Omalomena Maggy Cycas Revoluta
 	
	Opaco - Matt



Terriccio
Potting soil
Blumenerde
Terreau
Substrato

2/3

1/3

Argilla espansa
Expanded clay
Blähton
Argile expansée
Arcilla expandida

**Nico's
tips**



Contiene perfettamente
Designed to contain
Enthält
Conçu pour contenir
Diseñado para contener





Art. Arkè Family
Col. P
Mix
IN OUT
Opaco - Matt

NEW SIZE 11-15

Arkè

	COD.	1 2 3	cm.							
12 PCS	3911	11	1 x 9 h.	4310	P	T	B	GRG	CP	SA
	3915	15	15 x 12 h.	4314	P	T	B	GRG	CP	SA
6 PCS	3916	16	17 x 16 h.	4316/18	P	T	B	GRG	CP	SA
	3918	18	18,5 x 18,2 h.	4318	P	T	B	GRG	CP	SA
	3922	22	22,5 x 22,5 h.	4322	P	T	B	GRG	CP	SA
	3926	26	26 x 26 h.	4324	P	T	B	GRG	CP	SA
3 PCS	3930	30	30 x 30 h.	4328	P	T	B	GRG	CP	SA
	3936	36	36 x 35 h.	4335	P	T	B	GRG	CP	SA
	3942	42	42 x 40 h.	4342	P	T	B	GRG	CP	SA



Riserva d'acqua integrata
Integrated water reservoir
Integriertes Wasserreservoir
Reservoir d'eau intégré
Reserva de agua integrada



Contiene perfettamente
Designed to contain
Enthält
Conçu pour contenir
Diseñado para contener

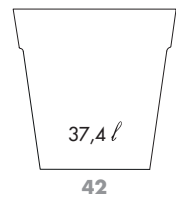
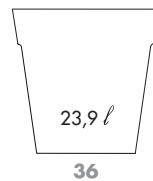
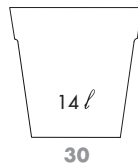
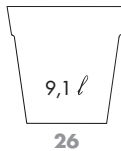
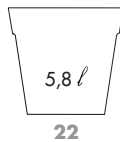



Think Creative

Dai spazio alla tua fantasia.

Crea la soluzione più adatta ai tuoi spazi.

Give room to your imagination.

Create the solution that best suits your spaces.

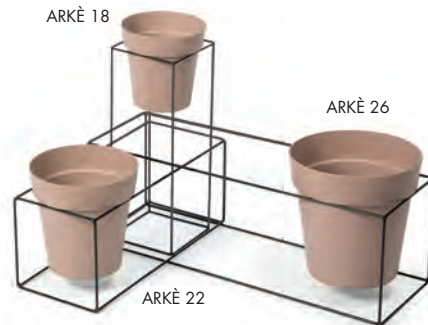

NEW PRODUCT

Kit Portavaso Arkè Small

KIT
CODE



ABBINABILE A - MATCHING WITH
PASSEND ZU - COMBINABLE AVEC
SE COMBINA CON



8401N	14 x 14 x 14 h.	ARKÈ 15	
	15,5 x 15,5 x 20 h.	ARKÈ 16	

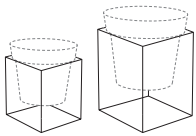

Contiene perfettamente
Designed to contain
Enthält
Conçu pour contenir
Diseñado para contener
ARKÈ 15 - 16



Kit Portavaso
Arkè Small



Metallo verniciato a polveri - Powder coated metal
Pulverbeschichtetes Metall - Fer revêtu époxy
Hierro con recubrimiento en polvo

NEW PRODUCT

Kit Portavaso Arkè Medium

KIT
CODE



ABBINABILE A - MATCHING WITH
PASSEND ZU - COMBINABLE AVEC
SE COMBINA CON



8402N	17 x 17 x 50 h.	ARKÈ 18	
	21 x 21 x 60 h.	ARKÈ 22	
	24 x 24 x 70 h.	ARKÈ 26	

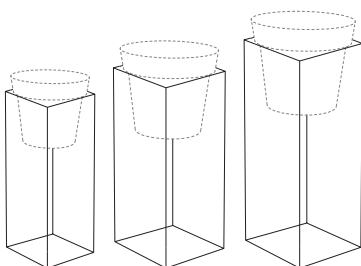

Contiene perfettamente
Designed to contain
Enthält
Conçu pour contenir
Diseñado para contener
ARKÈ 18 - 22 - 26

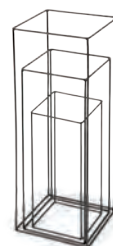

Kit Portavaso
Arkè Medium



Metallo verniciato a polveri - Powder coated metal
Pulverbeschichtetes Metall - Fer revêtu époxy
Hierro con recubrimiento en polvo



Art. 3833
Col. SA
Pennisetum
Alopecuroides
Opaco - Matt



Riserva d'acqua integrata
Integrated water reservoir
Integriertes Wasserreservoir
Reservoir d'eau intégré
Reserva de agua integrada



Contiene perfettamente
Designed to contain
Enthält
Conçu pour contenir
Diseñado para contener

Arkè Slim

	COD.					
	3833	33	33 x 40 h.	4328	P T B GRG CP SA	
3 PCS						

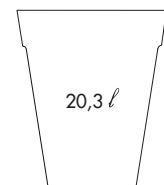

33

Guida sottovasi e coprivasi

Saucer and pot guide - Untersetzen- und Topfanleitung

Guide aux soucoupes et pots - Guía de platillos y macetas

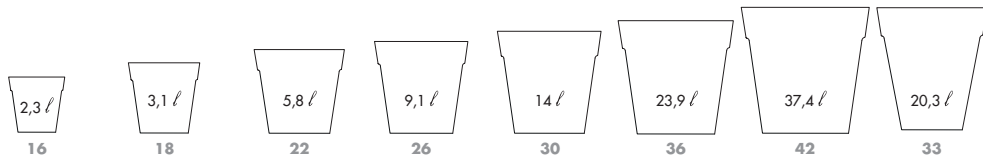

ARKÈ 16 ARKÈ 18 ARKÈ 22 ARKÈ 26 ARKÈ 30 ARKÈ 36 ARKÈ 42 ARKÈ SLIM 33

4316P	4318P	4322P	4324P	4328P	4335P	4342P	4328P
4316T	4318T	4322T	4324T	4328T	4335T	4342T	4328T
4316B	4318B	4322B	4324B	4328B	4335B	4342B	4328B
4318GRG	4318GRG	4322GRG	4324GRG	4328GRG	4335GRG	4342GRG	4328GRG
4318CP	4318CP	4322CP	4324CP	4328CP	4335CP	4342CP	4328CP
4318SA	4318SA	4322SA	4324SA	4328SA	4335SA	4342SA	4328SA

**SOTTOVASO ADATTO
SUITABLE SAUCER
PASSEND UNTERSETZER
SOUCOUBE CONSEILLÉ
PLATO ADECUADO**



PREMIUM 16	PREMIUM 18	PREMIUM 20 PREMIUM 22	PREMIUM 25	-	PREMIUM 35	PREMIUM 40	PREMIUM 30
------------	------------	--------------------------	------------	---	------------	------------	------------

**CONTIENE PERFETTAMENTE
DESIGNED TO CONTAIN
ENTHÄLT
CONÇU POUR CONTENIR
DISEÑADO PARA CONTENER**



Art. 3922
Col. B
Phalaenopsis
Opaco - Matt



Art. 6025 - 6040

Col. B

Mix







Opaco - Matt

Cassetta da balcone con riserva d'acqua e sistema di fissaggio integrati
Balcony flower box with integrated water reserve and fastening system
Balconnière avec réserve d'eau intégrée et système de fixation
Balkonblumenkasten mit integriertem Wasserreservoir und Befestigungssystem
Jardínera de balcón con reserva de agua y sistema de fijación integrado



Arkè Balcony 25

 COD.  25  25 x 23 x 18 h.  24,5 x 15 x 15 h.  P T B GRG CP SA



25



Riserva d'acqua integrata
con griglia di separazione

Integrated water reserve
with separation grid

Integrierte Wasserreserve
mit Trenngitter

Réserve d'eau intégrée
avec grille de séparation

Reserva de agua integrada
con rejilla de separación

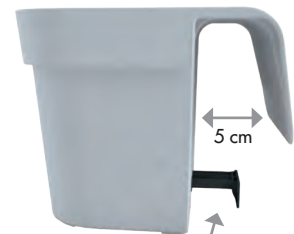

Distanziatore regolabile
Adjustable spacer
Einstellbarer Abstandhalter
Entretoise réglable
Espaciador ajustable



Fori di drenaggio sul fondo
Drainage holes in the bottom
Trous de drainage au fond
Abflusslöcher im Topfboden
Agujeros de drenaje en el fondo

Arkè Balcony 40



COD.



6040

40

38 x 23 x 18 h.

37,5 x 15 x 15 h.

P

T

B

GRG

CP

SA

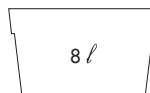

8 l

40





Art. 3750

Col. B

Mix



Opaco - Matt

Arkè Cassetta

COD.



3
PCS

3740	40	39 x 16,9 x 13,7 h.	5740	<input type="radio"/> P	<input type="radio"/> T	<input type="radio"/> B	<input type="radio"/> GRG	<input type="radio"/> CP	<input type="radio"/> SA
3750	50	49 x 16,9 x 13,7 h.	5750	<input type="radio"/> P	<input type="radio"/> T	<input type="radio"/> B	<input type="radio"/> GRG	<input type="radio"/> CP	<input type="radio"/> SA

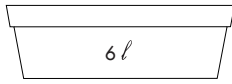

40

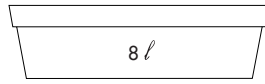

50



P



T



B

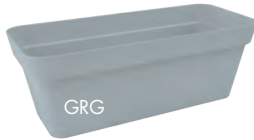

GRG

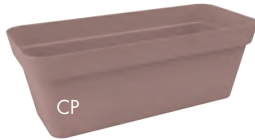

CP



SA



Riserva d'acqua integrata
Integrated water reservoir
Integriertes Wasserreservoir
Reservoir d'eau intégré
Reserva de agua integrada



abbinabile a - matching with - passend zu - combinable avec - se combina con

Sottocassetta Domus

COD.



5740	40	<input type="radio"/> P	<input type="radio"/> T	<input type="radio"/> B	<input type="radio"/> GRG	<input type="radio"/> CP	<input type="radio"/> SA
5750	50	<input type="radio"/> P	<input type="radio"/> T	<input type="radio"/> B	<input type="radio"/> GRG	<input type="radio"/> CP	<input type="radio"/> SA



Balconiera Fissa

COD.



8140	40	<input type="radio"/> N
8150	50	<input type="radio"/> N





NEW PRODUCT

Arkè Quadro

	COD.				
	8640	40	38,7 x 38,7 x 38,5 h.	5040	

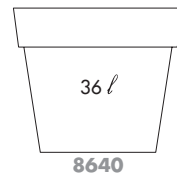

Sottovaso Quadro Mega



COD.



6
PCS

5040

40

P

T

B

GRG

CP

SA

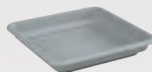

ABBINAMENTI CONSIGLIATI - SUGGESTED MATCHES



Fori di drenaggio sul fondo
Drainage holes in the bottom
Trous de drainage au fond
Abflusslöcher im Topfboden
Agujeros de drenaje en el fondo

Art. 8640

Col. T

Olea Europaea

Opaco - Matt

Nico's
tips



GARDEN STYLE
ORIGIN DECOR

Mix&Match

Crea la soluzione più adatta mescolando forme e colori.
Create the best solution by mixing colors and surfaces!



ABBINAMENTI CONSIGLIATI - SUGGESTED MATCHES

Arkè Cassettone



NEW PRODUCT

Arkè Cassettone

	COD.				
	8380	80	38,7 x 78 x 38,5 h.	2380	

Disponibile dal / Available as from: Novembre / November 2023

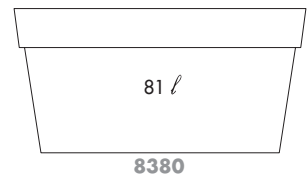



Art. 8380
 Col. P
 Bombuseae
 Opaco - Matt

GARDEN STYLE
 ORIGIN DECOR



Fori di drenaggio sul fondo
 Drainage holes in the bottom
 Troux de drainage au fond
 Abflusslöcher im Topfboden
 Agujeros de drenaje en el fondo

Sottocassettone Mega

COD. 1 2 3
 3 PCS 2380 80 P T B GRG CP SA



ABBINAMENTI CONSIGLIATI - SUGGESTED MATCHES

Mix&Match

Crea la soluzione più adatta mescolando forme e colori.
 Create the best solution by mixing colors and surfaces!



ABBINAMENTI CONSIGLIATI - SUGGESTED MATCHES
 Arkè Quadro



Rinforzo metallico di contenimento incluso
 Metal reinforcement included
 Metallverstärkung enthalten
 Renforcement métallique inclus
 Refuerzo metálico incluido







Create to
inspire





Art. Verve Family
 Col. RU - T
 Mix
 Lucido - Gloss

Verve

	COD.		 cm								
	1011	11	11 x 10 h.		T	B	LA	PI	RU	CP	SA
	1013	13	13 x 12,1 h.		T	B	LA	PI	RU	CP	SA
	1015	15	15 x 14 h.		T	B	LA	PI	RU	CP	SA
	1018	18	17,9 x 17 h.		T	B	LA	PI	RU	CP	SA
	1020	20	20 x 19 h.		T	B	LA	PI	RU	CP	SA



ø 30 e 35 cm provvisti di rulli
 ø 30 and 35 cm equipped with rollers
 ø 30 und 35 cm mit Rollen inklusiv
 ø 30 et 35 cm munie de rouleaux
 ø 30 y 35 cm con ruedas incluidas

Verve

COD.



3
PCS

1025	25	25 x 22 h.	T	B	RU
1030	30	30 x 27 h.	T	B	RU
1035	35	35 x 32 h.	T	B	RU



11



13



15



18



20

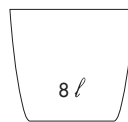

25

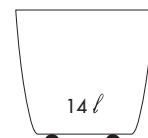

30

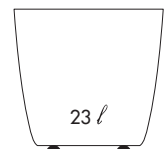

35



Art. 1015

Col. TR

Mix



Trasparente - Clear

Crystal

collection

GARDEN STYLE
ORIGIN DECOR

Verve Crystal

COD.



1013TR	13	13 x 12,1 h.	TR
1015TR	15	15 x 14 h.	TR
1018TR	18	17,9 x 17 h.	TR

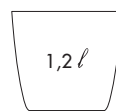

1,2 l

13



1,9 l

15

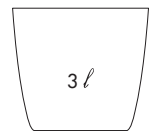

3 l

18



TR



Art. 1213

Col. CP

 Sansevieria



Lucido - Gloss

Verve Slim

COD.



6
PCS

1213

13

13,3 x 15,6 h.

T

B

LA

PI

RU

CP

SA

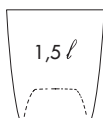

13

Nico's tips

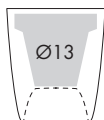

Contiene perfettamente
Designed to contain
Enthält
Conçu pour contenir
Diseñado para contener





Crystal

collection



Verve Slim Crystal

COD.		
1213TR	13	13,3 x 15,6 h.

6
PCS

TR

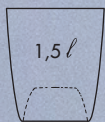

13

Contiene perfettamente
Designed to contain
Enthält
Conçu pour contenir
Diseñado para contener

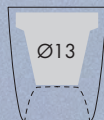



Art. 1213

Col. TR

 Phalaenopsis



Trasparente - Clear







Art. 6130







Col. LA

 Sansevieria
Laurentii

 Lucido - Gloss

Verve Ciotola

COD.  1 2 3  31,5 x 15 h. 

 10 l
30

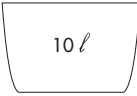

Nico's tips



Contiene perfettamente
 Designed to contain
 Enthält
 Conçu pour contenir
 Diseñado para contener

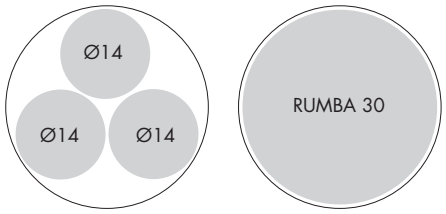

Verve Quadro



COD.										
12 PCS	1311	11	11 x 11 x 11,7 h.	T	B	LA	PI	RU	CP	SA
	1313	13	13 x 13 x 13,9 h.	T	B	LA	PI	RU	CP	SA
6 PCS	1315	15	15 x 15 x 16 h.	T	B	LA	PI	RU	CP	SA
	1320	20	20 x 20 x 21 h.	T	B	LA		RU	CP	SA

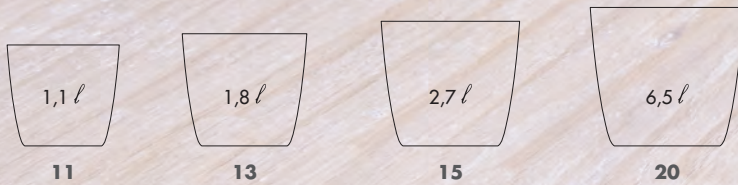



Art. 1311 - 1313
1315 - 1320

Col. CP

 Mix



Lucido - Gloss



Art. 1440 - 1430
Col. B
Mix
Lucido - Gloss

Verve Cassetta

COD.	1 2 3	cm	T	B	LA	RU	CP	SA	Capacity
1440	40	39 x 13 x 12,5 h.	●	○	●	●	○	○	5,2 l 40
1430	30	30 x 15 x 13,5 h.	●	○	●	●	○	○	5 l 30
1445	45	44,4 x 15 x 13,5 h.	●	○	●	●	○	○	7,5 l 45



40



30



45



ø12 X 3



ø14 X 2



ø14 X 3



Contiene perfettamente
Designed to contain
Enthält
Conçu pour contenir
Diseñado para contener

ORIGIN ESSENTIAL

collection



GARDEN STYLE
ORIGIN ESSENTIAL

Un'ampia gamma di prodotti leggeri e resistenti dedicati a chi apprezza la funzionalità. Realizzati in polipropilene riciclato effetto matt si prestano all'utilizzo sia in esterni che interni. Forme progettate per abbinare estetica e praticità con colori moderni e accorgimenti tratti dal mondo del florovivaismo. Realizzati con materiali amici dell'ambiente riciclabili al 100%.

A wide range of lightweight and resistant products, dedicated to people who appreciate functionality. Made using 100% recycled and recyclable polypropylene with matt finish, they are the perfect solution for outdoors and interiors. The shapes are designed to combine aesthetic with practicality, the colors are modern. Made using environmentally-friendly materials.

Eine Auswahl von leichten und starken Produkten. Hergestellt aus recyceltem Polypropylen mit matt-Effekt, sie sind eine ideale Lösung für Terrassen, Garten und im Haus. Die Produkte verbinden Ästhetik und Funktionalität, moderne Farben und Erfahrung aus der grüne Welt. Hergestellt aus 100% wiederverwertbaren Materialien.

Une large gamme de produits légers et résistants, dédiés à qui apprécie la fonctionnalité. Fabriqués en polipropilene recyclé finition matt ils sont idéal pour les terrasses, les jardins et les intérieurs. Formes conçues pour combiner esthétique et praticité avec des couleurs modernes et d'astuces qui viennent du monde de l'horticulture.

Una amplia gama de productos ligeros y resistentes, dedicados aquellos que aprecian la funcionalidad. Fabricados en polipropileno reciclado con efecto matt pueden ser empleadas en tanto externos como internos. Formas diseñadas para combinar estética y practicidad, con colores modernos y con la experiencia del mundo de la floricultura. Hechos con materiales ecológicos 100% reciclables.



LIGHTWEIGHT



STACKABLE



SHOCK
RESISTANT



RECYCLABLE



MADE IN
ITALY



Injection moulding





GARDEN STYLE
ORIGIN ESSENTIAL

NEW COLOURS

Premium



COD.		 cm.	
2416	16	15,9 x 11,5 h.	4316
2418	18	17,9 x 12,9 h.	4318
2420	20	19,7 x 14 h.	4320
2422	22	21,9 x 15,7 h.	4320
2425	25	24,7 x 17,6 h.	4324
2430	30	29,7 x 21,3 h.	4328
2435	35	34,7 x 24,8 h.	4335
2440	40	39,7 x 27,7 h.	4335
2445	45	44,7 x 31,2 h.	4342
2450	50	49,6 x 35 h.	4350
2460	60	59,4 x 40,5 h.	4356
2480	80	79 x 51,7 h.	4374

C	P	T	B	OP					
C	P	T	B						
C	P	T	B	GRG	CP	SA	VRO		
C	P	T	B	GRG	CP	SA	VRO		
C	P	T	B	GRG	CP	SA	VRO		
C	P	T	B	GRG	CP	SA	VRO		
C	P	T	B	GRG	CP	SA	VRO		
C	P	T	B						
C	P	T	B						
C	P	T	B						

10 PCS

3 PCS

1 PCS



PREMIUM 2416 OP

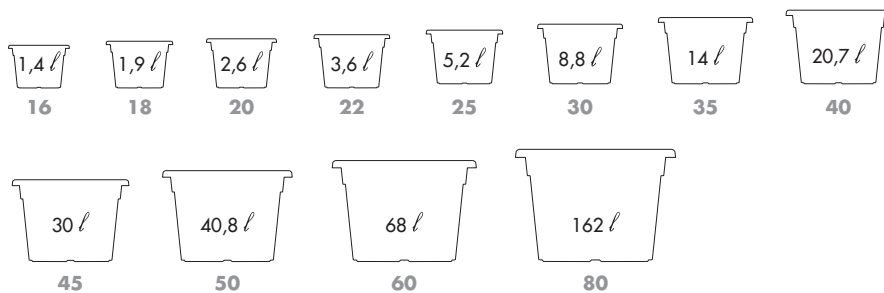



Sottovaso Domus Pg. 79





GARDEN STYLE
ORIGIN ESSENTIAL

Art.	2420
Col.	C
	Palisias
 	Opaco - Matt

GARDEN STYLE
ORIGIN ESSENTIAL



Art. 4720

Col. P

 Calandola

Opaco - Matt

Kit Premium



COD.



4720

20

19,7 x 14 h.

4318

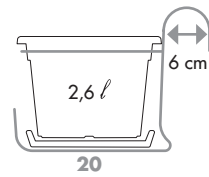

Vaso completo di sottovaso e balconiera
 Pot with saucer and metal hanger already assembled
 Töpfe mit Untersetzer und Metallhalterung voll eingebaut
 Pot avec soucoupe et support déjà assemblée
 Vaso con plato y hierro ya montado

GARDEN STYLE
 ORIGIN ESSENTIAL

Kit Premium wall



COD.



5120

20

19,7 x 14 h.

4318

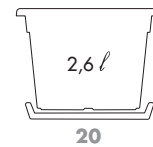

Vaso completo di sottovaso e balconiera
 Pot with saucer and metal hanger already assembled
 Töpfe mit Untersetzer und Metallhalterung voll eingebaut
 Pot avec soucoupe et support déjà assemblée
 Vaso con plato y hierro ya montado

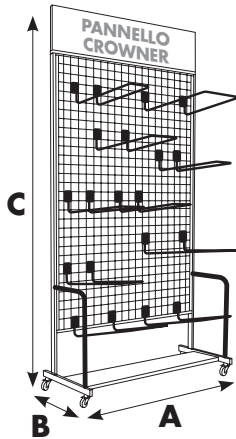

EXPO DISPLAY

COD.	A x B x C cm
8901N	104 x 46 x 210 h.

Metallo verniciato a polveri
Powder coated metal
Pulverbeschichtetes
Metall Fer revêtu époxy
Hierro con recubrimiento en polvo

Think Creative

AUMENTA LE VENDITE
CON GLI EXPO VISUAL NICOLI.

INCREASE SALES WITH
NICOLI'S VISUALS EXPO.

Nico's
tips



PANNELLO
CROWNER



Pannello bifacciale / Double-sided crowner

NEW COLOUR

Sottovaso Domus



COD.



4310	10	10 x 1,7 h.	6,5	C	V	P														
4312	12	12 x 2 h.	8	C	V	P														
4314	14	14 x 2,2 h.	9,5	C	V	P														
4316	16	16 x 2,5 h.	11	C	V	P	T	B	OP											
4318	18	18 x 2,8 h.	12,5	C	V	P	T	B	GRG	CP	SA									
4320	20	20 x 3,1 h.	14	C	V	P	T	B	GRG	CP	SA	VRO								
4322	22	22 x 3,4 h.	15,5	C	V	P	T	B	GRG	CP	SA									
4324	24	24 x 3,7 h.	17	C	V	P	T	B	GRG	CP	SA	VRO								
4326	26	26 x 4 h.	18,5	C	V	P														
4328	28	28 x 4,2 h.	20	C	V	P	T	B	GRG	CP	SA	VRO								
4330	30	30 x 4,6 h.	21,5	C	V	P														
4335	35	35 x 5,2 h.	25	C	V	P	T	B	GRG	CP	SA	VRO								
4342	42	42 x 6,3 h.	30	C	V	P	T	B	GRG	CP	SA									
4350	50	50 x 7,5 h.	36	C	V	P	T	B												
4356	56	56 x 7,3 h.	45,5	C			P	T	B											
4374	74	74 x 9,6 h.	61	C			P	T	B											

10
PCS

3
PCS



GARDEN STYLE
ORIGIN ESSENTIAL

SOTTOVASI DOMUS ABBINABILI A - MATCHING WITH - PASSEND FÜR COMBINABLE AVEC - SE COMBINA CON

	VASO PREMIUM	ARKÈ	ARKÈ SLIM	CIOTOLONE
4310	-	-	-	-
4312	-	-	-	-
4314	-	-	-	-
4316	2416	3916	-	-
4318	2418	3916/18	-	-
4320	2420/2422	-	-	-
4322	-	3922	-	5430
4324	2425	3926	-	-
4326	-	-	-	-
4328	2430	3930	3833	5440
4330	-	-	-	-
4335	2435/2440	3936	-	-
4342	2445	3942	-	5450
4350	2450	-	-	-
4356	2460	-	-	5460
4374	2480	-	-	-





Art. 33A20 - 33A35
Col. CP
Mix
Opaco - Matt

Ciotola completa già assemblata - Bowl already assembled - Schale voll eingebaut - Coupe déjà assemblé - Cuenco completo ya montado

Rumba Assemblata



COD.										
		cm.	cm.	C	V	P	T	B	CP	SA
33A18	18	18 x 9 h.		<input type="checkbox"/>	<input type="checkbox"/>	<input type="checkbox"/>	<input type="checkbox"/>	<input type="checkbox"/>		
33A20	20	20 x 9,5 h.		<input type="checkbox"/>	<input type="checkbox"/>	<input type="checkbox"/>	<input type="checkbox"/>	<input type="checkbox"/>	<input type="checkbox"/>	<input type="checkbox"/>
33A22	22	22 x 10 h.		<input type="checkbox"/>	<input type="checkbox"/>	<input type="checkbox"/>	<input type="checkbox"/>	<input type="checkbox"/>	<input type="checkbox"/>	<input type="checkbox"/>
33A25	25	25 x 12 h.		<input type="checkbox"/>	<input type="checkbox"/>	<input type="checkbox"/>	<input type="checkbox"/>	<input type="checkbox"/>	<input type="checkbox"/>	<input type="checkbox"/>
33A30	30	30 x 13,5 h.		<input type="checkbox"/>	<input type="checkbox"/>	<input type="checkbox"/>	<input type="checkbox"/>	<input type="checkbox"/>	<input type="checkbox"/>	<input type="checkbox"/>
33A35	35	35 x 15 h.		<input type="checkbox"/>	<input type="checkbox"/>	<input type="checkbox"/>	<input type="checkbox"/>	<input type="checkbox"/>	<input type="checkbox"/>	<input type="checkbox"/>
33A40	40	40 x 15,5 h.		<input type="checkbox"/>	<input type="checkbox"/>	<input type="checkbox"/>	<input type="checkbox"/>	<input type="checkbox"/>		

10
Pcs





GARDEN STYLE
ORIGIN ESSENTIAL





Ari. 5460

Col. C

Hydrangea



Opaco - Matt

Ciotolone



COD.



5430

30

30 x 15 h.

4322

C P T

5440

40

40 x 17 h.

4328

C P T

5450

50

50 x 17 h.

4342

C P T

5460

60

60 x 17 h.

4356

C P T

10
PCS

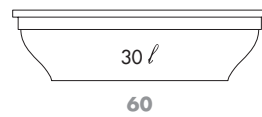
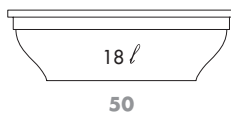
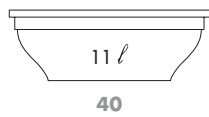
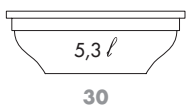



Art. Firenze Ass.
Col. C
Nematanthus
Hypocirta
IN OUT
Opaco - Matt

Ciotola completa già assemblata - Bowl already assembled - Schale voll eingebaut - Coupe déjà assemblé - Cuenco completo ya montado

Firenze Assemblata



COD.



64A18	18	18 x 8,5 h.	C
64A20	20	20 x 9 h.	C
64A22	22	22 x 10 h.	C
64A25	25	25 x 10 h.	C
64A30	30	30 x 12 h.	C
64A35	35	35 x 13 h.	C
64A40	40	40 x 14 h.	C

10
PCS





GARDEN STYLE
ORIGIN ESSENTIAL

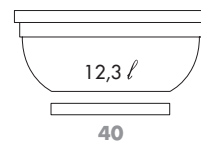
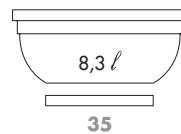
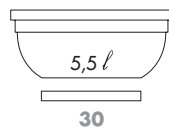
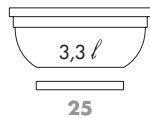

Basket Siena Assemblato



COD.

6814	14	14,4 x 10,3 h.	32	C	B			
6816	16	16,5 x 11,4 h.	38	C	B			
6818	18	18,3 x 12,8 h.	38	C	B			
6820	20	20,5 x 14,3 h.	48	C	B	LA	PI	RN
6822	22	22,5 x 15,4 h.	48	C	B	LA	PI	RN
6825	25	25 x 16,9 h.	48	C	B	LA	PI	RN

10
PCS



Basket completo già assemblato - Hanging Basket assembled - Basket voll eingebaut -
Suspension déjà assemblé - Cuenco colgante completo ya montado

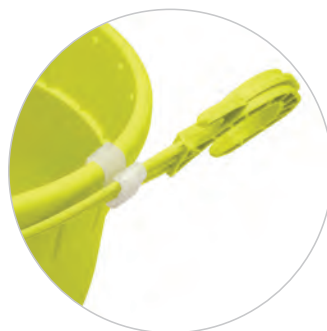
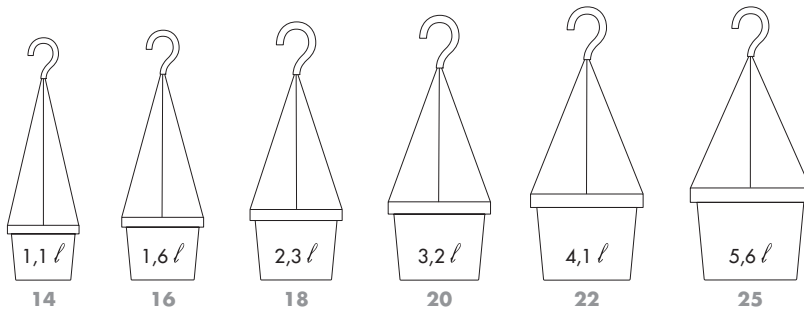



GARDEN STYLE
ORIGIN ESSENTIAL

Art. 6820
Col. LA - B
Sundaville
Opaco - Matt



Art. 4940 - 5040
 Col. VRO
 Calluna vulgaris
 Opaco - Matt

NEW COLOUR

Quadro Mega



COD.



4920	20	20 x 20 x 17,3 h.	5020	C	P	T	B	GRG
4925	25	24,7 x 24,7 x 21,6 h.	5025	C	P	T	B	GRG
4930	30	31,5 x 31,5 x 28 h.	5030	C	P	T	B	GRG
4940	40	38,5 x 38,5 x 34 h.	5040	C	P	T	B	GRG VRO
4945	45	44 x 44 x 40 h.	5045	C	P	T	B	GRG VRO

6
PCS

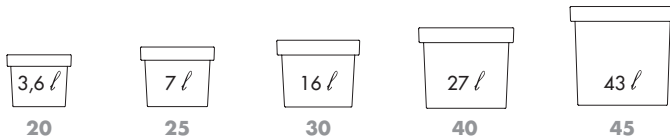

20

25

30

40

45



Mix&Match

Crea la soluzione più adatta mescolando forme e colori.

Create the best solution by mixing colors and surfaces!



ABBINAMENTI CONSIGLIATI - SUGGESTED MATCHES

Quadro Mega 30 - Cassettone Mega 60
 Quadro Mega 40 - Cassettone Mega 80
 Quadro Mega 45 - Cassettone Mega 100

GARDEN STYLE
 ORIGIN ESSENTIAL



NEW COLOUR

Sottovaso Quadro Mega



COD.



COD.	cm.	cm.	h.	C	P	T	B	GRG	VRO
5020	20	17 x 17	3 h.	●	●	●	●	●	
5025	25	22 x 22	3,5 h.	●	●	●	●	●	
5030	30	28,5 x 28,5	4,5 h.	●	●	●	●	●	
5040	40	34 x 34	5,5 h.	●	●	●	●	●	●
5045	45	39 x 39	6,5 h.	●	●	●	●	●	●

6
 PCS

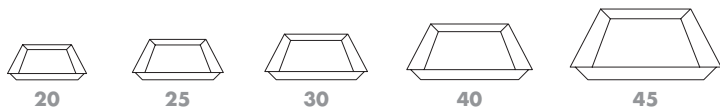



Art. 2280 - 2380
Col. VRO
Sundaville
IN OUT
Opaco - Matt

NEW COLOUR

Cassettone Mega



COD.	1 2 3	cm.	OPTIONAL	OPTIONAL										
						C	P	T	B	GRG	VRO			
2260	60	62 x 31,5 x 28 h.	-											
2280	80	80 x 40 x 34 h.	4 x 73R											
22100	100	100 x 45 x 40 h.	6 x 73R											

3
PCS



80-100 cm:

Rinforzo metallico di contenimento incluso
Metal reinforcement included
Metallverstärkung enthalten
Renforcement métallique inclus
Refuerzo metálico incluido

Capienza elevata
High capacity
Hohe Kapazität
Grande capacitat
Alta capacidad

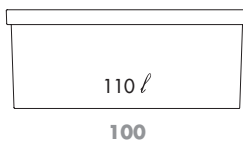
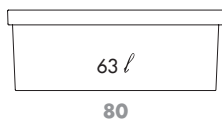
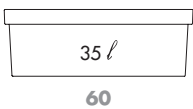



Mix&Match

Crea la soluzione più adatta mescolando forme e colori.

Create the best solution by mixing colors and surfaces!



ABBINAMENTI CONSIGLIATI - SUGGESTED MATCHES

Cassettone Mega 60 - Quadro Mega 30

Cassettone Mega 80 - Quadro Mega 40

Cassettone Mega 100 - Quadro Mega 45

GARDEN STYLE
ORIGIN ESSENTIAL



NEW COLOUR

Sottocassettone Mega



COD.



2360 60 60 x 29 x 7,5 h.

C P T B GRG

2380 80 75 x 34 x 6 h.

C P T B GRG VRO

23100 100 94 x 40 x 6,5 h.

C P T B GRG VRO

3
PCS

Ruote

COD.



1
PCS

7301 4

C

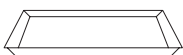

60



80

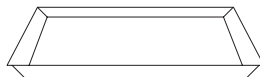

100



Art. 5640 - 5740
5660 - 5760

Col. T

Begonia

Opaco - Matt

NEW COLOURS

Cassetta Domus



COD.	1 2 3	cm.										
5640	40	40 x 20 x 16 h.	5740	C	V	P	T	B	GRG	CP	SA	VRO
5650	50	50 x 20 x 16 h.	5750	C	V	P	T	B	GRG	CP	SA	VRO
5660	60	60 x 20 x 16 h.	5760	C	V	P	T	B	GRG	CP	SA	VRO
5680	80	80 x 20 x 16 h.	5780	C	V	P	T					

10
PCS



80 cm:

Rinforzo metallico di contenimento incluso
Metal reinforcement included
Metallverstärkung enthalten
Renforcement métallique inclus
Refuerzo metálico incluido

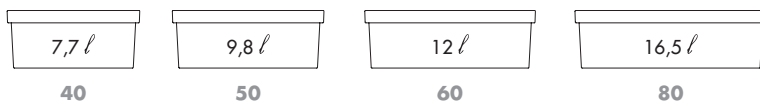

Balconiera Fissa

COD.	1 2 3		
8140	40	Z	
8150	50	Z	
8160	60	Z	

10
PCS

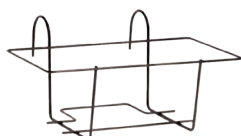

Metallo verniciato a polveri - Powder coated metal
Pulverbeschichtetes Metall - Fer revêtu époxy
Hierro con recubrimiento en polvo



GARDEN STYLE
ORIGIN ESSENTIAL

NEW COLOURS

Sottocassetta Domus



COD.



5740	40	38,5 x 17,5 x 4 h.	C	V	P	T	B	GRG	CP	SA	VRO
5750	50	48,5 x 17,5 x 4 h.	C	V	P	T	B	GRG	CP	SA	VRO
5760	60	58,5 x 17,5 x 4 h.	C	V	P	T	B	GRG	CP	SA	VRO
5780	80	78,5 x 17,5 x 4 h.	C	V	P	T					

10
PCS

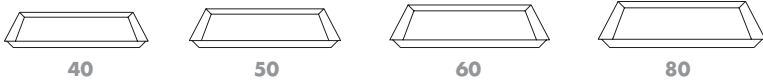

Balconiera Regolabile

COD.



8840	40	N
8850	50	N
8860	60	N

10
PCS

Metallo verniciato a polveri - Powder coated metal
Pulverbeschichtetes Metall - Fer revêtu époxy
Hierro con recubrimiento en polvo

Cassetta Patio



COD.



7745	45	45 x 25 x 19 h.	IN	C
7755	55	55 x 25 x 19 h.	IN	C

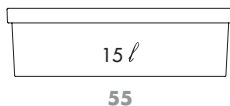
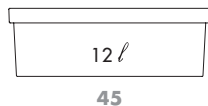

Cassetta completa di Sottocassetta - Window-box with saucer assembled - Kasten mit Untersetzer eingebaut -
Cassette et soucoupe déjà assemblées - Jardinera y plato completo ya montado

GARDEN STYLE
ORIGIN ESSENTIAL



Controllo dell'acqua - Water control system
Bewässerungssystem - Système de contrôle de l'eau
Control del agua



Balconiera Patio Fissa

COD.



8245	45	N
8255	55	N

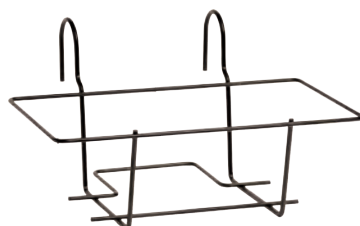



GARDEN STYLE
ORIGIN ESSENTIAL

Art. 7745
Col. C
Celosia Caracas
Opaco - Matt



Kit Supporti Primavera



COD.

2702

N



Metallo verniciato a polveri 2 pz - Powder coated metal 2 pcs
Pulverbeschichtetes Metall 2 Stk - Fer revêtu époxy 2 pcs
Hierro con recubrimiento en polvo 2 pz



Rinforzo metallico di contenimento incluso 1 pz
Metal reinforcement included 1 pcs
Metallverstärkung enthalten 1 Stk
Renforcement métallique inclus 1 pcs
Refuerzo metálico incluido 1 pz

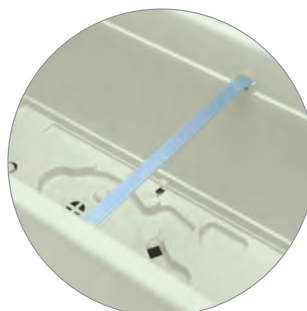



Cassetta Primavera



COD.



10
PCS

2540	40	39,6 x 19,8 x 16,9 h.	IN	C	P	T	B	CP	SA
2550	50	49,6 x 19,8 x 16,9 h.	IN	C	P	T	B	CP	SA
2560	60	59,6 x 19,8 x 16,9 h.	IN	C	P	T	B	CP	SA

Cassetta completa di sottocassetta - Window-box and saucer assembled - Kasten mit Untersetzer eingebaut - Casette et soucoupe déjà assemblées - Jardinera y plato completo ya montado

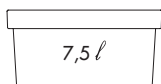

40

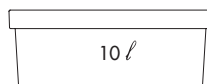

50

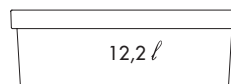

60

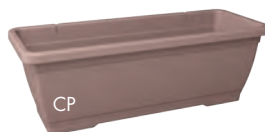

GARDEN STYLE
ORIGIN ESSENTIAL

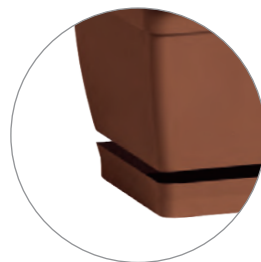

ABBINABILE A - MATCHING WITH - PASSEND ZU
COMBINABLE AVEC - SE COMBINA CON

Balconiera Fissa

COD.



10
PCS

8140	40	Z
8150	50	Z
8160	60	Z





Art. 2580

Col. SA























 Dipladenia

Opaco - Matt

Cassetta completa di sottocassetta e balconiera - Window-box with saucer and hanger already assembled - Kasten mit Untersetzer und Metallhalterung voll eingebaut - Cassette avec soucoupe et support déjà assemblés - Jardinera completa con plato y hierro

Kit Primavera

COD.		 cm.							
				C	P	T	B	CP	SA
2840	40	39,6 x 19,8 x 16,9 h.	IN						
2850	50	49,6 x 19,8 x 16,9 h.	IN						
2860	60	59,6 x 19,8 x 16,9 h.	IN						

 10
PCS

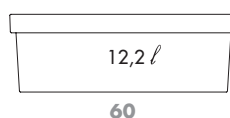
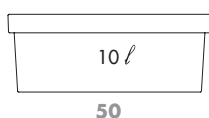
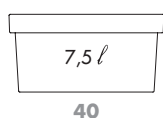



Ottima Impilabilità
Good Stackability
Gut Stapelbar
Bonne Empilabilité
Alta Apilabilidad





Art.	48A20
Col.	LA - PI
	Bouvardia
	Opaco - Matt

Cassetta e sottocassetta completa già assemblata - Window-box already assembled - Kasten voll eingebaut - Cassette déjà assemblée - Jardinera completa ya montada

Balconcino Assemblata



COD.



48A20	20	21,7 x 11,5 x 8,5 h.					
48A30	30	31,7 x 11,5 x 8,5 h.					
48A40	40	41,7 x 11,5 x 8,5 h.					

10
PCS

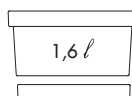

20

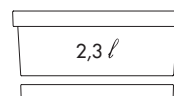

30

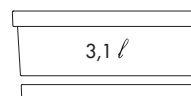

40



Balconiere e supporti metallici

Metal frame holders

Nico's tips



Balconiera Fissa

Flower box holder

COD.				
8140	40	38,5 x 19	6 cm Ø	
8150	50	48,5 x 19	6 cm Ø	
8160	60	58,5 x 19	6 cm Ø	

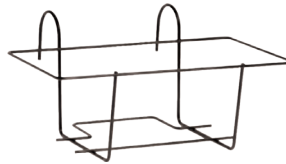

ABBINABILE A - MATCHING WITH - PASSEND ZU - COMBINABLE AVEC - SE COMBINA CON

Arkè Cassetta - Cassetta Primavera
Cassetta Eden - Mysia

Balconiera Regolabile

Adjustable flower box holder

COD.				
8840	40	37 x 18,5 x 13,5 h.	min. 3 cm max. 18 cm	
8850	50	47 x 18,5 x 13,5 h.	min. 3 cm max. 18 cm	
8860	60	57 x 18,5 x 13,5 h.	min. 3 cm max. 18 cm	

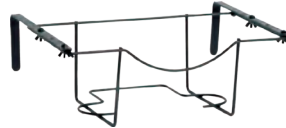

ABBINABILE A - MATCHING WITH - PASSEND ZU - COMBINABLE AVEC - SE COMBINA CON

Cassetta Eden - Mysia

Balconiera Patio Fissa

Patio flower box holder

COD.				
8245	45	39,5 x 20	6 cm Ø	
8255	55	49,5 x 20	6 cm Ø	

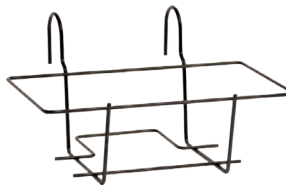

ABBINABILE A - MATCHING WITH - PASSEND ZU - COMBINABLE AVEC - SE COMBINA CON

Cassetta Patio

Kit Supporti Primavera

Primavera brackets set

COD.		
2702	6 cm Ø	



ABBINABILE A - MATCHING WITH - PASSEND ZU - COMBINABLE AVEC - SE COMBINA CON

Cassetta Primavera

GARDEN STYLE
ORIGIN ESSENTIAL

EVOLUTION ELEGANCE & MATT

collection

Una gamma innovativa realizzata in Resina di Polietilene con finitura Opaca. La caratterizza una qualità superiore, la finitura a mano di ogni singolo pezzo, grande attenzione alle tendenze e cura dei dettagli. I colori sono pensati per avvicinarsi alla materia naturale e alle esigenze di decorazione contemporanea. Una tecnica produttiva che garantisce resistenza e solidità, permettendo di realizzare prodotti leggeri anche nelle dimensioni più importanti.

Una soluzione ideale per interni ed esterni in quanto resistente alle basse temperature e ai raggi UV.

An innovative range made by polyethylene resin with a MATT finish. Featuring superior quality, hand finishing of each piece, attention to trends and care over details. The colors are conceived to get closer to the natural material and to the contemporary decoration styles.

This production technique ensures resistance and solidity and makes it possible to create lightweight products, even in the largest sizes. Resistant to low temperatures and UV rays it is the perfect solution for interiors and outdoors.

Eine innovative Sortiment aus Polyethylenharz mit MATT Oberflächen, höhen Design und Qualität, Handfertigung von jedem Produkt, Beachtung zu den Tendenzen und Obhut für die Detailen. Die Farben sind inspiriert von den natürlichen Materialien und zu den zeitgemäßen Dekorationsstilen. Eine Herstellungstechnik die die Stärke und Festigkeit sichert und die Erfüllung von leichten Produkten ermöglicht, auch in den grössten Ausmaßen. Eine ideale Lösung für Terrassen, Garten und zu Hause.

Une gamme innovante réalisée par de la résine de Poliéthilène avec finition MATT.

Une gamme caractérisée par une qualité supérieure, finition à la main de chaque pièce et une grande attention aux détails et aux tendances. Les couleurs sont conçues pour se rapprocher de la matière naturelle et aux styles de décoration contemporains.

Une technique de production qui garantit la résistance et la durabilité, ce qui nous permet de créer des produits légers, même dans les dimensions les plus importantes. Une solution idéale pour une utilisation en intérieur et extérieur car résistant à basses températures et aux rayons UV.

Una gama innovadora fabricada en resina de polietileno con un acabado MATT. Se caracteriza por la calidad superior, el acabado a mano para cada producto, atención a las tendencias y atención al detalle. Los colores tienen el propósito de estar más cerca del material natural y a los estilos de decoración contemporáneos.

Una técnica de producción que garantiza resistencia y durabilidad, lo que permite crear productos ligeros, incluso en las dimensiones más importantes. Una solución ideal para uso en interiores y exteriores, resistente a bajas temperaturas y a los rayos UV.

GARDEN STYLE
EVOLUTION



L.L.D.P.E. Rotational moulding



UV
RESISTANT



HAND
FINISHED



LIGHTWEIGHT



SHOCK
RESISTANT



IN / OUT



+80°C
-60°C



RECYCLABLE



MADE IN
ITALY

ROTO
moulding

GARDEN STYLE
EVOLUTION



Colours Palette

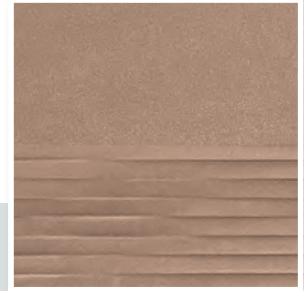

GARDEN STYLE
AV - Avana



GARDEN STYLE
B - Bianco

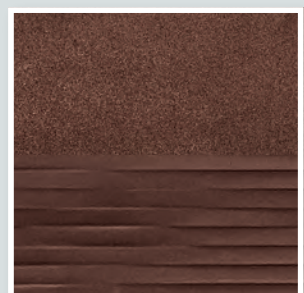

GARDEN STYLE
CT - Corten

GARDEN STYLE
EVOLUTION

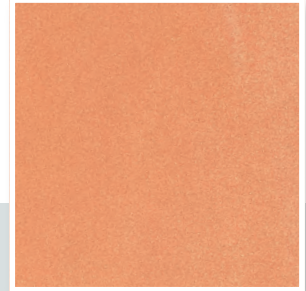

GARDEN STYLE
I - Impruneta

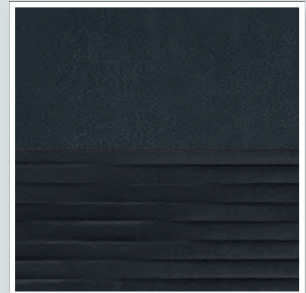

GARDEN STYLE
P - Antracite



GARDEN STYLE
S - Cenere

GARDEN STYLE
EVOLUTION

Custom Colours

Personalizza la tua collezione,
con la gamma colori a richiesta.

Customize your collection,
with the color range upon request.

COLORI CON SFUMATURE – SHADED COLOURS



AV
AVANA



S
CENERE



CT
CORTEN



I
IMPRUNETA



P
ANTRACITE



AN
ANTICATO

COLORI OMOGENEI – FLAT COLOURS



B
BIANCO



ZA
ZAFFERANO



CR
CREMISI



VR
VERDE ROSMARINO



FA
FANGO



LM
LIME

Se desideri un articolo con un colore diverso
dalla gamma a catalogo, oggi puoi ordinare la tua
collezione, con un minimo di 10 pezzi per articolo.

If you would like an item in a different colour from
the catalogue range, you can order your collection
today, with a minimum of 10 pieces per item.





Custom
Colours



Art. R0533
Col. P
Cypress Goldcrest
IN OUT
Opaco - Matt



AV



CT



P



S





finitura materica in rilievo
textured embossed finish





GARDEN STYLE
EVOLUTION

Talos Elegance

 1 PCS	COD.	 cm.	 cm.		
	R0533	33 x 70 h.	27 x 26,5 h.	R1630	

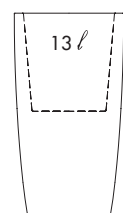

R0533



Art. R2733 - R2743



Col. B

Mix



Opaco - Matt

Talos Matt

COD.	 cm	 cm		AV	B	P	S
R2733	33 x 70 h.	27 x 30 h.	R1630	<input checked="" type="radio"/>	<input type="radio"/>	<input type="radio"/>	<input type="radio"/>
R2743	43 x 90 h.	35,5 x 38 h.	R1636	<input checked="" type="radio"/>	<input type="radio"/>	<input type="radio"/>	<input type="radio"/>

1
PCS

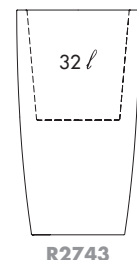
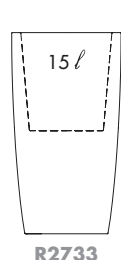

Nico's tips



PG. 194

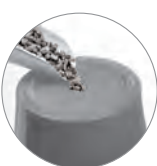

Più stabilità?
More stability?
Mehr Stabilität?
Plus de stabilité?
Más estabilidad?

GARDEN STYLE
EVOLUTION

Tylus Elegance



COD.

R6830



30 x 40 h.



25,5 x 37,5 h.



R1626

AV

CT

P

S

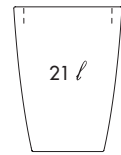

R6830



AV



CT



P



S

*finitura materica in rilievo
textured embossed finish*



GARDEN STYLE
EVOLUTION



Art. R6830

Col. CT

Pachira

Opaco - Matt

Tylus Matt

COD.



R4323	23 x 30 h.	19 x 27 h.	—
R4330	30 x 40 h.	25,5 x 37 h.	R1626
R4340	40 x 53 h.	34 x 25 h.	R1636



1
PCS



R4323

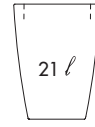

R4330

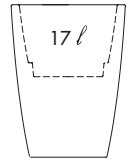

R4340



Art. Tylus Matt

Col. P

Sundaville



Opaco - Matt

GARDEN STYLE
EVOLUTION



Art. Rhea Elegance

Col. S

Aspidistra
Kenzia



Opaco - Matt













finitura materica in rilievo
textured embossed finish





GARDEN STYLE
EVOLUTION

Rhea Elegance

	COD.	 cm.	 cm.		
	R7330	30 x 30 h.	25,3 x 28 h.	R1630	   
	R7340	40 x 40 h.	33,8 x 37,5 h.	R1636	   

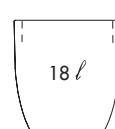

R7330

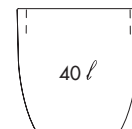

R7340



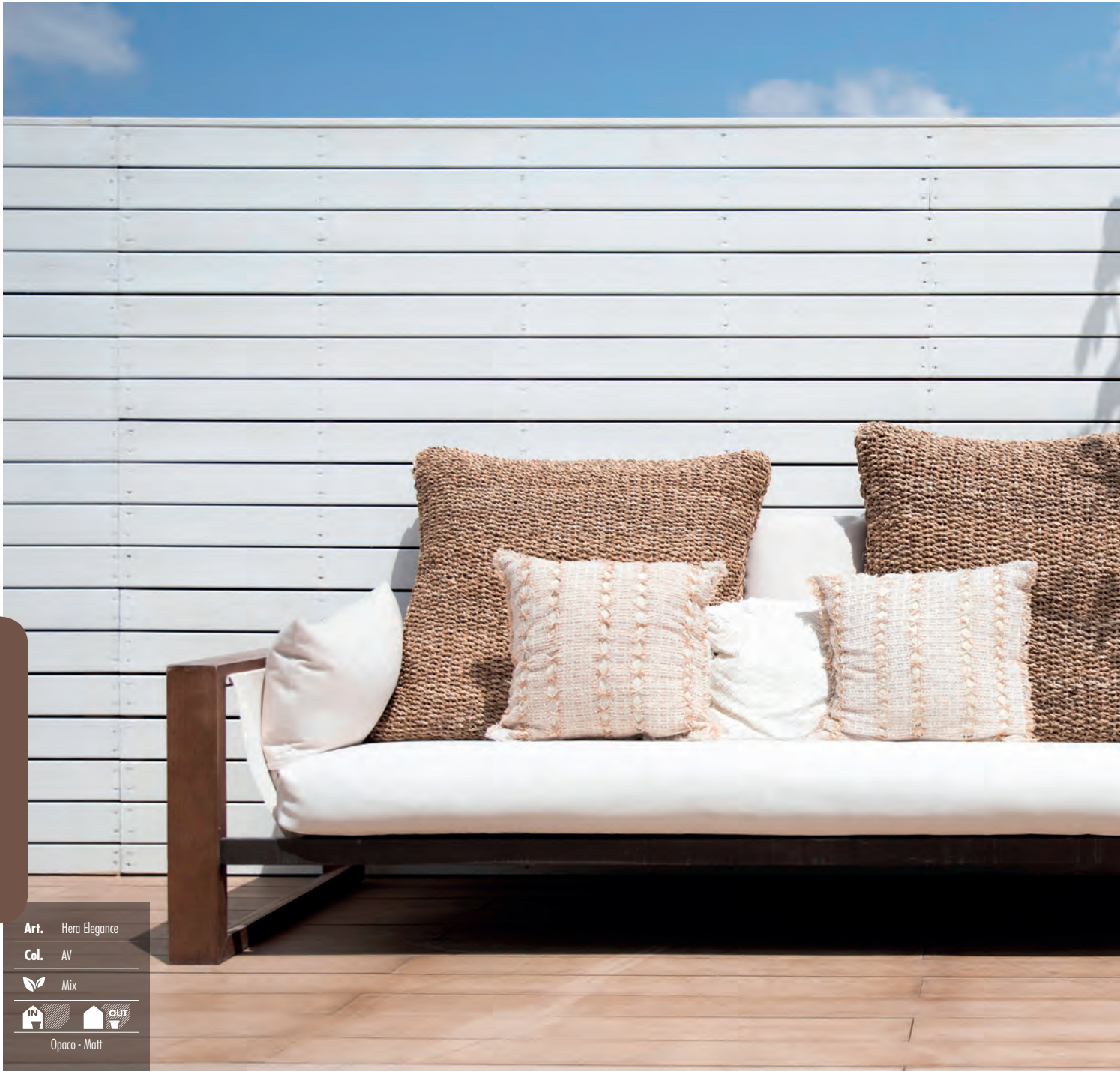

Art. Hero Elegance

Col. AV

Mix



Opaco - Matt



finitura materica in rilievo
textured embossed finish





GARDEN STYLE
EVOLUTION

Hera Elegance

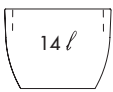
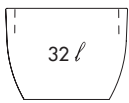
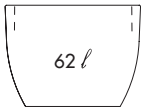
COD.	 cm.	 cm.		AV CT P S	 14 l	 32 l	 62 l
R0730	30 x 23 h.	25 x 20 h.	R1630	AV CT P S	R0730	R0740	R0750
R0740	40 x 30 h.	34 x 27 h.	R1642	AV CT P S			
R0750	50 x 38 h.	42 x 35 h.	R1648	AV CT P S			









Art. Hera
Col. AV
 Mix
 Opaco - Matt

Hera

COD.				
R3830	30 x 23 h.	25 x 20 h.	R1630	<input checked="" type="radio"/> AV <input type="radio"/> B <input type="radio"/> P <input type="radio"/> S
R3840	40 x 30 h.	34 x 27 h.	R1642	<input checked="" type="radio"/> AV <input type="radio"/> B <input type="radio"/> P <input type="radio"/> S
R3850	50 x 38 h.	42 x 35 h.	R1648	<input checked="" type="radio"/> AV <input type="radio"/> B <input type="radio"/> P <input type="radio"/> S
R3860	60 x 45 h.	51 x 42 h.	R1658	<input checked="" type="radio"/> AV <input type="radio"/> B <input type="radio"/> P <input type="radio"/> S

1 PCS

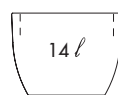

R3830

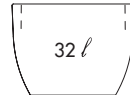

R3840

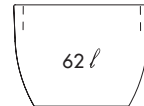

R3850

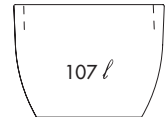

R3860



AV



B













S



P

GARDEN STYLE
EVOLUTION

Hermes Elegance

COD.	 cm.	 cm.			AV	CT	P	S
R7230	30 x 26 h.	26,3 x 24 h.	R1630					
R7240	40 x 35 h.	34,8 x 32,2 h.	R1636					

1
PCS

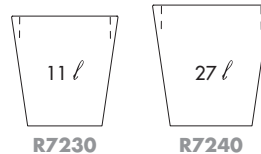

GARDEN STYLE
EVOLUTION

finitura materica in rilievo
textured embossed finish





GARDEN STYLE
EVOLUTION

Art.	Hermes Elegance
Col.	P
	Ficus
 	Opaco - Matt





Ares

COD.				<input type="radio"/>	<input type="radio"/>	<input type="radio"/>	
R3920	20 x 25 h.	17 x 22 h.	—	<input type="radio"/> B	<input checked="" type="radio"/> P	<input type="radio"/> S	
1 PCS	R3930	30 x 37,5 h.	25,5 x 34,5 h.	R1630	<input type="radio"/> B	<input checked="" type="radio"/> P	<input type="radio"/> S
	R3940	40 x 50 h.	33,5 x 47 h.	R1636	<input type="radio"/> B	<input checked="" type="radio"/> P	<input type="radio"/> S

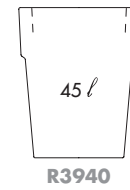
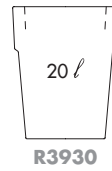

GARDEN STYLE
EVOLUTION

Art. R3930
 Col. B
 Crassula ovata
 Gollum
 Opaco - Matt



Art. R7160



Col. P

 Hydrangea

Opaco - Matt

Zeus Matt

COD.				
R7130	30 x 26 h.	26 x 25 h.	R1626	AV CT P S
R7140	40 x 35 h.	34,5 x 34 h.	R1632	AV CT P S
R7150	50 x 43,5 h.	43,5 x 42,5 h.	R1642	AV CT P S
R7160	60 x 52 h.	52 x 51 h.	R1648	AV CT P S

1
PCS



R7130



R7140

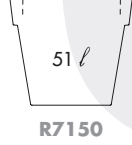

R7150

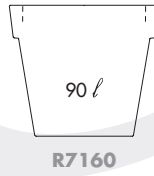













R7160



GARDEN STYLE
EVOLUTION

Chiron

	COD.	 cm.	 cm.					
	R6050	50 x 29 h.	42 x 26 h.	R1632				
	R6060	60 x 36 h.	51 x 33 h.	R1636				

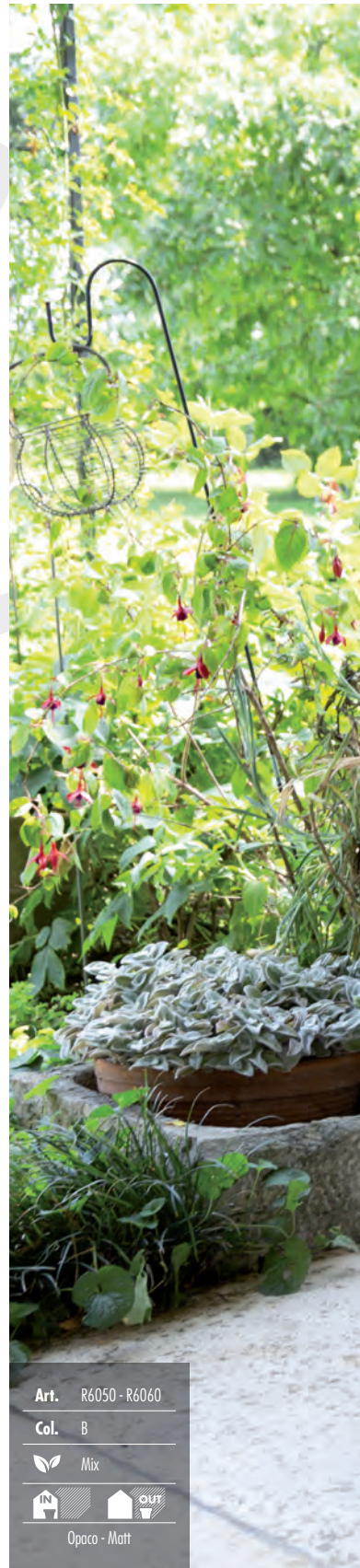
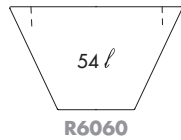
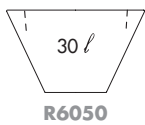

Art. R6050 - R6060

Col. B

Mix

IN OUT

Opaco - Matt





Art. R0135 - R0155







Col. I

Buxus
Macrophylla
Rotundifolia



Opaco - Matt

Doppio Bordo Liscio

COD.	 cm.	 cm.		
R0135	35 x 28 h.	30 x 25 h.	R1626	
R0145	45 x 35 h.	39 x 32 h.	R1636	
R0155	55 x 45 h.	47,5 x 42 h.	R1642	
R0175	75 x 61,5 h.	66 x 58,5 h.	R1658	

PCS

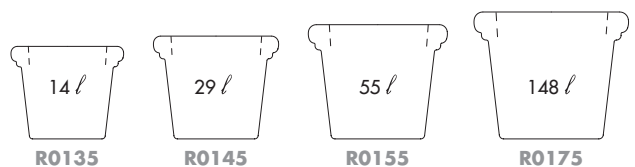

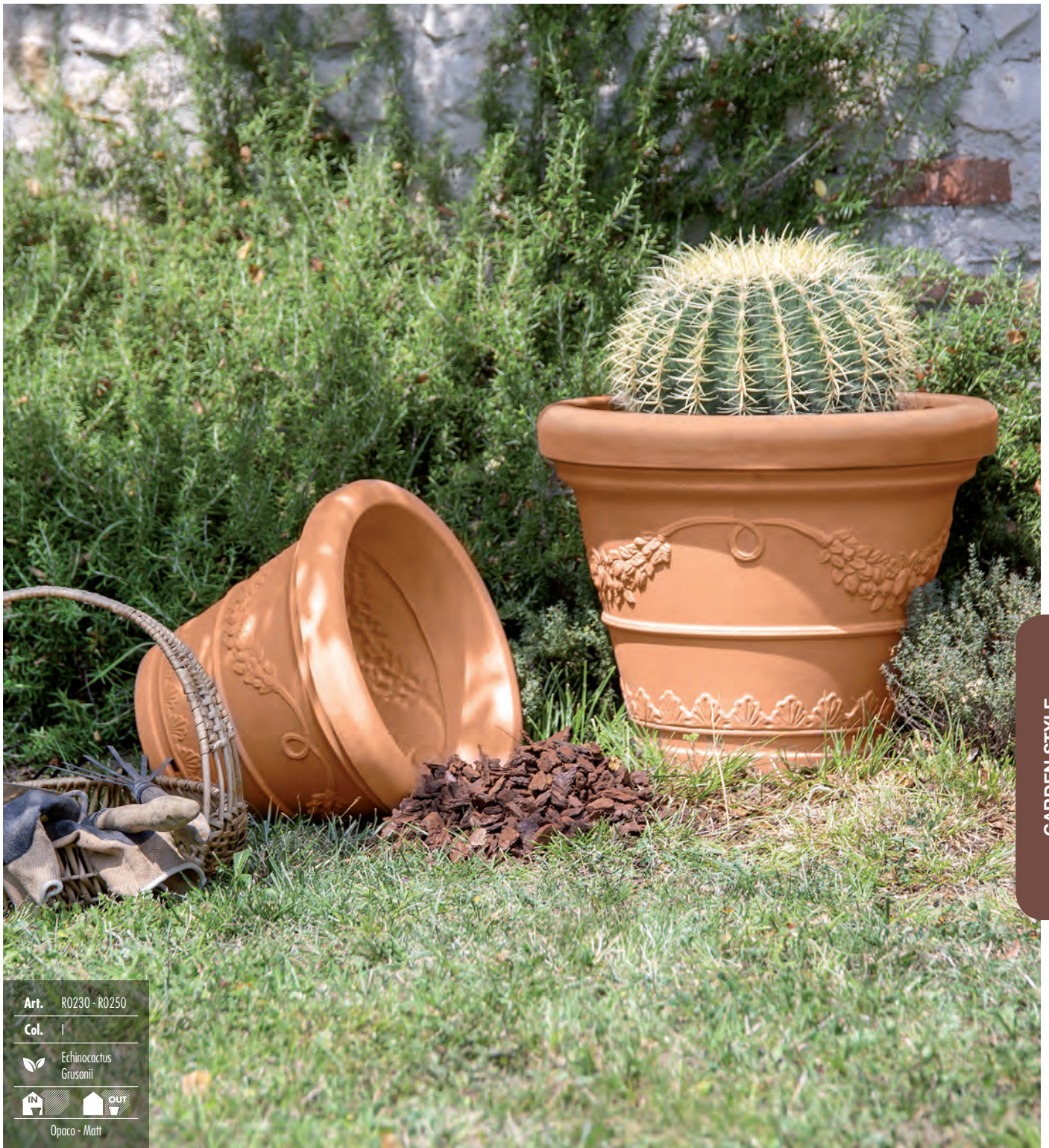







GARDEN STYLE
EVOLUTION

Art. R0230 - R0250
 Col. I
 Echinocactus
 Grusonii
 Opaco - Matt

Doppio Bordo Festonato

COD.				
R0230	30 x 24 h.	25 x 21 h.	R1626	
R0240	40 x 32 h.	33 x 29 h.	R1630	
R0250	50 x 40,5 h.	41,5 x 37,5 h.	R1636	
R0260	60 x 48 h.	50 x 45 h.	R1642	



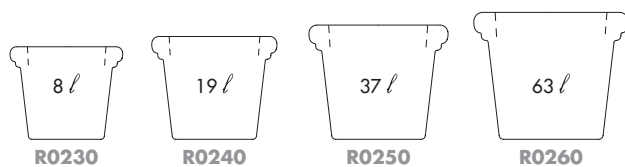



1
PCS



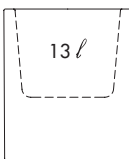
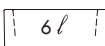
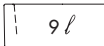

NEW PRODUCTS

Echo

COD.	 cm.	 cm.		AV	B	P	S			
R5525	25 x 12 h.	20 x 12 h.	-	AV	B	P	S			
R5530	30 x 14 h.	25 x 13 h.	-	AV	B	P	S			
R5535	35 x 42 h.	29 x 24 h.	R1642	AV	B	P	S			

1
PCS

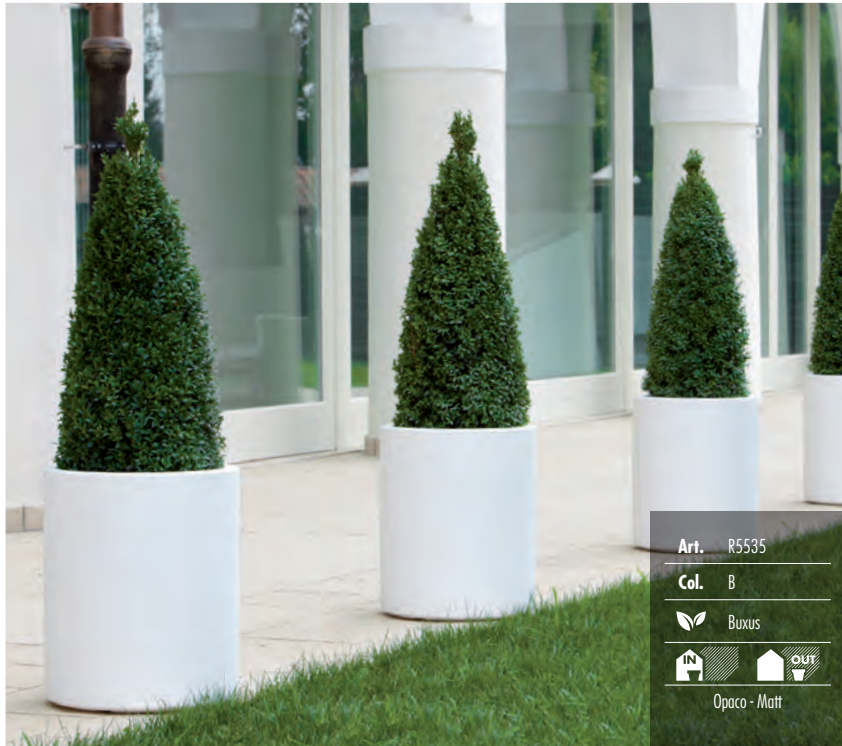

Nico's tips

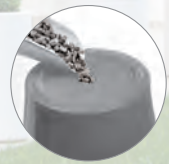

Art. R5535
 Col. B
 Buxus
 Opaco - Matt

Più stabilità?
 More stability?
 Mehr Stabilität?
 Plus de stabilité?
 Más estabilidad?
 PG. 194

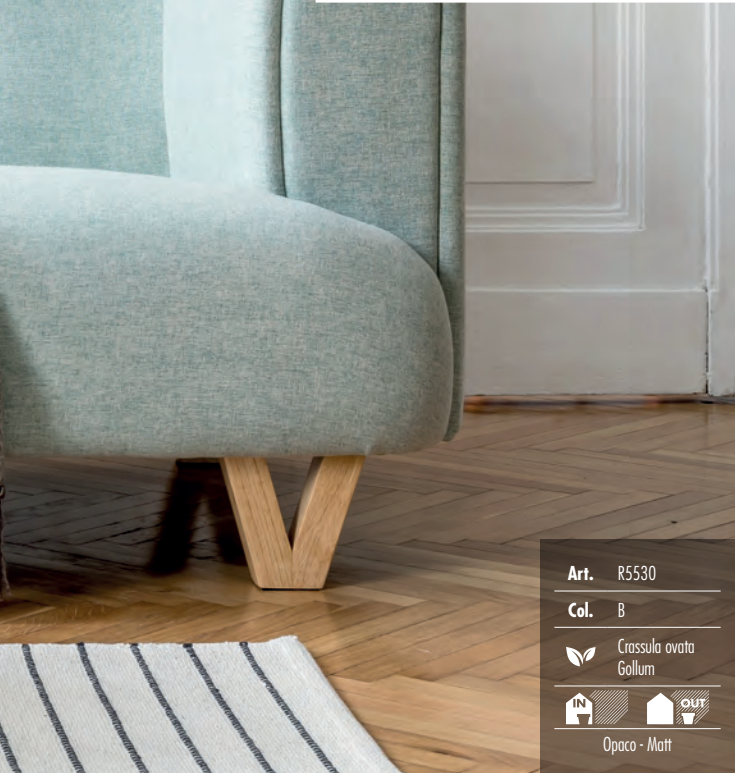

Art. R5530
 Col. B
 Crassula ovata
 Gollum
 Opaco - Matt

Nico's tips



Terriccio
 Potting soil
 Blumenerde
 Terreau
 Substrato

2/3

1/3

Argilla espansa
 Expanded clay
 Blähton
 Argile expansée
 Arcilla expandida



GARDEN STYLE
 EVOLUTION



Art. R1626

Col. AV

 Mix

Opaco - Matt

Think Creative



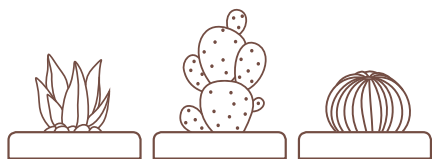

Dai spazio alla tua fantasia.





Give room to your imagination.

Atlas Sottovaso

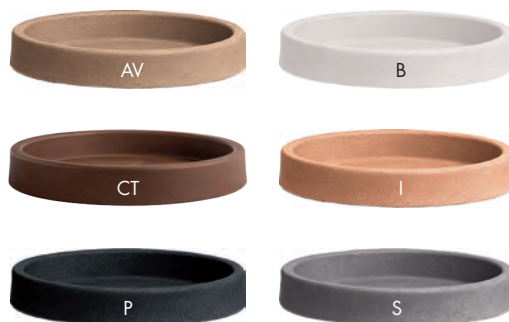
COD.	 cm.	 cm.	AV	B	CT	I	P	S
R1626	26 x 3,5 h.	22 x 3 h.	●	○	●	●	●	●
R1630	30 x 3,7 h.	25,5 x 3,2 h.	●	○	●	●	●	●
R1632	32,5 x 3,9 h.	27 x 3,4 h.	●	○	●	○	●	●
R1636	36,5 x 4,2 h.	30 x 3,7 h.	●	○	●	●	●	●
R1642	42,5 x 5 h.	36 x 4,5 h.	●	○	●	●	●	●
R1648	48,5 x 5,3 h.	42 x 4,8 h.	●	○	●	○	●	●
R1652	52,5 x 5,3 h.	46 x 4,8 h.	●	○	○	○	●	●
R1658	58,5 x 5,8 h.	51 x 5,3 h.	●	○	○	●	●	●



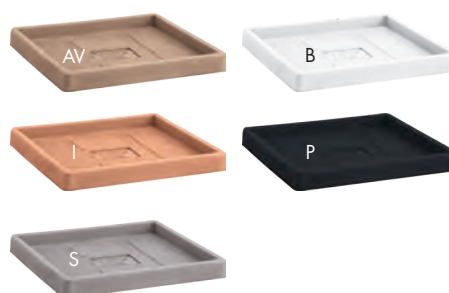

Themis Sottovaso Quadro

COD.	 cm.	 cm.	AV	B	I	P	S
R3540	39 x 39 x 4,5 h.	35 x 35 x 4 h.	●	○	●	●	●



Themis Sottocassetta

COD.	 cm.	 cm.	AV	B	I	P	S
R3460	60,5 x 30,5 x 4 h.	56,5 x 26,5 x 3,5 h.	○	○	○	○	○
R3480	79 x 39 x 4,5 h.	75 x 35 x 4 h.	●	○	●	●	●
R3499	99 x 39 x 4,5 h.	95 x 35 x 4 h.	●	○	●	●	●

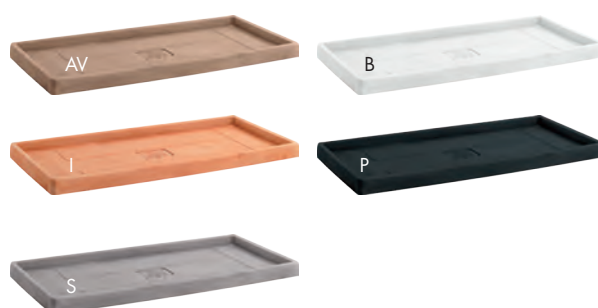

GARDEN STYLE
EVOLUTION



Art. R0940

Col. AV

Bonsai

IN OUT

Opaco - Matt



Thetis Elegance

	COD.						
R0930	30 x 12 h.	26 x 10 h.	R1630				
R0940	40 x 16 h.	36 x 13 h.	R1642				

R0930	R0940



GARDEN STYLE
EVOLUTION

finitura materica in rilievo
textured embossed finish







NEW SIZE 30

Thetis

COD.	cm.		R				
	↓	↔		AV	B	P	S
R4230	30 x 12 h.	26 x 10 h.	R1630	●	○	●	○
R4240	40 x 16 h.	36 x 13 h.	R1642	●	○	●	○
R4250	50 x 20 h.	43 x 17 h.	R1648	●	○	●	○
R4260	60 x 24 h.	52 x 21 h.	R1658	●	○	●	○

1
PCS

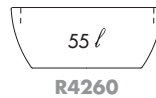
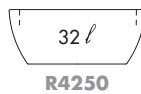
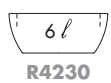

Art. R4250

Col. P

Rhipsalis
Cassutha



Opaco - Matt

GARDEN STYLE
EVOLUTION



Art. R4050

Col. B

Mix



Opaco - Matt

Athena

COD.



R4050 50 x 29 x 23 h. 46 x 25 x 20 h.

AV B P S

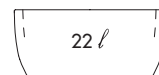

R4050



GARDEN STYLE
EVOLUTION





Art. R5260

Col. B

 Sansevieria
Crassula

Opaco - Matt

Iris

COD.



1
PCS

R5260

60 x 20 x 18 h. 56 x 14 x 15 h.

AV

B

P

S

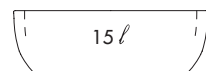

R5260



GARDEN STYLE
EVOLUTION



the kitchen garden

basil



sage



basil



rosemary



chili pepper



rosemary



mint



sage



mint



Art. R5132

Col. P

Mix



Opaco - Matt

Clio

COD.

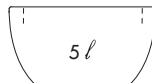

R5132

32 x 18 x 21 h.

28 x 14 x 20 h.

P

S

R5132

Think Creative

The Aromatic Garden - Der Kräutergarten
Le jardin d'arômes - El jardín aromático

Menta-Mint-Minze-Menthe-Menta



Mentha

Peperoncino-Chili pepper-Chili-Piment-Chile



Capsicum

Basilico-Basil-Basilikum-Basilic-Albahaca



Ocimum basilicum

Rosmarino-Rosemary-Rosmarin-Romarin-Romero



Rosmarinus officinalis

Salvia-Sage-Salbei-sage-Salvia



Salvia officinalis

Erba cipollina-Chives-Schnittlauch-Ciboulette-Cibollino



Allium schoenoprasum

Prezemolo-Parsley-Petersilie-Persil-Persilij



Petroselinum crispum

Timo-Thyme-Thymian-Thym-Tomillo



Thymus

Origano-Origan-Oregano-Origan-Orégano



Origanum vulgare

GARDEN STYLE
EVOLUTION

GARDEN STYLE
EVOLUTION



Art. R6250
Col. B
Ptilotus Exaltatus
Opaco - Matt

Calypso Matt

COD.



1
PCS

R6250

50,3 x 20 x 18,2 h.

45,3 x 15 x 15,3 h.

AV B P S

11 l

R6250



GARDEN STYLE
EVOLUTION

Nico's
tips



Terriccio
Potting soil
Blumenerde
Terreau
Substrato

2/3

1/3

Argilla espansa
Expanded clay
Blähton
Argile expansée
Arcilla expandida

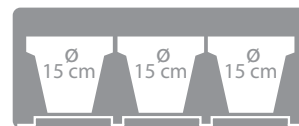

Contiene perfettamente
Designed to contain
Enthält
Conçu pour contenir
Diseñado para contener



Art. R4540

Col. S

 Aloe



Opaco - Matt

Mysia

COD.



R4540 40 x 20 x 18 h. 36 x 17 x 15 h.

AV B P S

R4550 50 x 20 x 18 h. 46 x 17 x 15 h.

AV B P S

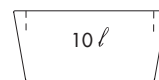

R4540

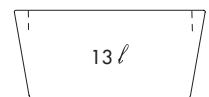

R4550





GARDEN STYLE
EVOLUTION



Art. R4540
Col. AV
Gazania
Opaco - Matt

ABBINABILE A - MATCHING WITH - PASSEND ZU
COMBINABLE AVEC - SE COMBINA CON

Balconiera Fissa

COD. 

10
PCS

8140	40	
8150	50	

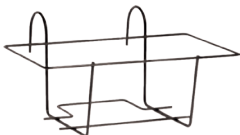



ABBINABILE A - MATCHING WITH - PASSEND ZU
COMBINABLE AVEC - SE COMBINA CON

Balconiera Regolabile

COD. 

10
PCS

8840	40	
8850	50	
8860	60	

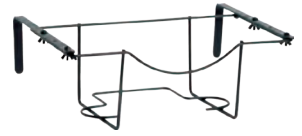

GARDEN STYLE
EVOLUTION



finitura materica in rilievo
textured embossed finish

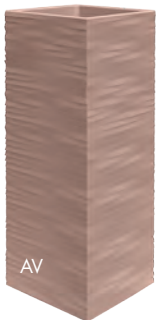



Art. R1030
 Col. AV
 Boxus
 Opaco - Matt

Nico's tips



Più stabilità?
 More stability?
 Mehr Stabilität?
 Plus de stabilité?
 Más estabilidad?



PG. 194

Nico's tips



Terriccio
 Potting soil
 Blumenerde
 Terreau
 Substrato

2/3

1/3

Argilla espansa
 Expanded clay
 Blähton
 Argile expansée
 Arcilla expandida

GARDEN STYLE
 EVOLUTION

NEW PRODUCT

Divo Elegance

COD. cm. cm.

1 PCS R1030 29,5 x 29,5 x 75 h. 24 x 24 x 26 h. AV CT P S



R1030

Mix&Match

Crea la soluzione più adatta mescolando forme e colori.
 Create the best solution by mixing colors and surfaces!

ABBINAMENTI CONSIGLIATI - SUGGESTED MATCHES
 Separe Elegance

Nico's tips





finitura materica in rilievo
textured embossed finish





Art. R0480
 Col. P - S
 Bambuseae
 Opaco - Matt

Nico's tips



Più stabilità?
 More stability?
 Mehr Stabilität?
 Plus de stabilité?
 Más estabilidad?



PG. 194

Nico's tips



Terriccio
 Potting soil
 Blumenerde
 Terreau
 Substrato

2/3

1/3

Argilla espansa
 Expanded clay
 Blähton
 Argile expansée
 Arcilla expandida

GARDEN STYLE
 EVOLUTION

Separè Elegance

COD. cm. cm.

1 PCS R0480 79 x 29,5 x 75 h. 74 x 24 x 26 h. AV CT P S

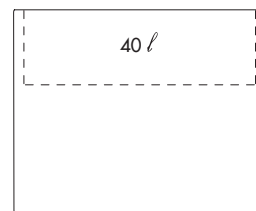

R0480

Nico's tips



Mix&Match

Crea la soluzione più adatta mescolando forme e colori.
 Create the best solution by mixing colors and surfaces!

ABBINAMENTI CONSIGLIATI - SUGGESTED MATCHES

Divo Elegance

Quadro Elegance

COD.



1
PCS

R6930	29,5 x 29,5 x 30 h.	23,5 x 23,5 x 27 h.	AV	CT	P	S
R6940	39,5 x 39,5 x 39,5 h.	31,5 x 31,5 x 34,5 h.	AV	CT	P	S

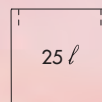

R6930

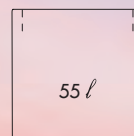

R6940



AV

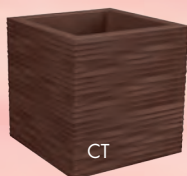

CT

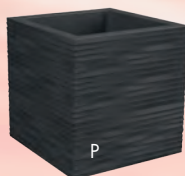

P

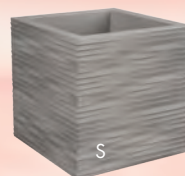

S

GARDEN STYLE
EVOLUTION



finitura materica in rilievo
textured embossed finish



Terriccio
Potting soil
Blumenerde
Terreau
Substrato

2/3

1/3

Argilla espansa
Expanded clay
Blähton
Argile expansée
Arcilla expandida

Nico's
tips



GARDEN STYLE
EVOLUTION



Art. R6940

Col. CT

 Citrus limon



Opaco - Matt

Cassettone Elegance

COD.



1
PCS

R7060	60 x 29,5 x 30 h.	54 x 23,5 x 27 h.
R7080	79 x 39,5 x 39,5 h.	71,5 x 31,5 x 34,5 h.

AV CT P S
AV CT P S



R7060



R7080

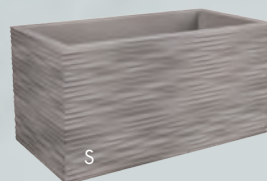
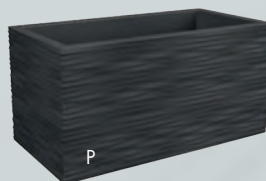
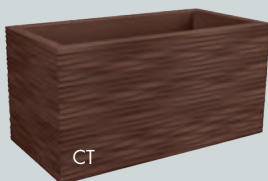
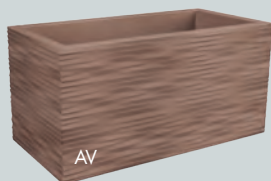

Nico's
tips



Terriccio
Potting soil
Blumenerde
Terreau
Substrato

2/3

1/3

Argilla espansa
Expanded clay
Blähton
Argile expansée
Arcilla expandida



Art. R7080

Col. S

Nephrolepis



Opaco - Matt

finitura materica in rilievo
textured embossed finish



GARDEN STYLE
EVOLUTION

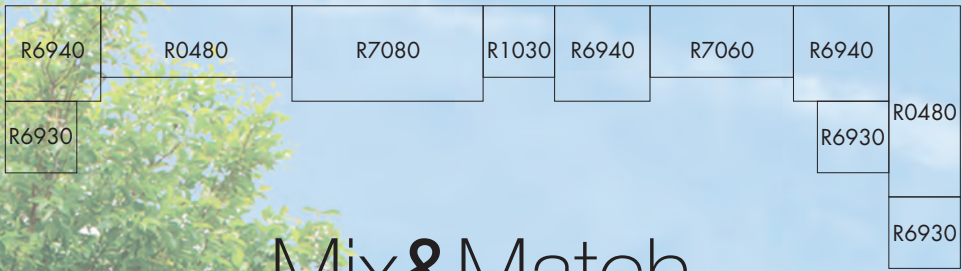

Mix&Match

GARDEN STYLE
EVOLUTION





GARDEN STYLE
EVOLUTION

Think
Creative

Modus quadro

COD. R6340 40 x 40 x 40 h. 31 x 31 x 30 h. **AV** **B** **P** **S**

 24 l
R6340



Carrello abbinabile art. F0522
 Matching trolley art. F0522
 Passend Trolley art. F0522
 Support à roulettes combinable art. F0522
 Set de ruedas aplicable art. F0522



Nico's tips



Terriccio
 Potting soil
 Blumenerde
 Terreau
 Substrato

2/3

1/3

Argilla espansa
 Expanded clay
 Blähton
 Argile expansée
 Arcilla expandida



GARDEN STYLE
EVOLUTION

Art. R6340
Col. P - B
Mix
Opaco - Matt

Nico's
tips



Terriccio
Potting soil
Blumenerde
Terreau
Substrato

2/3

1/3

Argilla espansa
Expanded clay
Blähton
Argile expansée
Arcilla expandida

Modus Cassetta

1 PCS	COD.	cm	cm	AV	B	P	S
	R6180	80 x 40 x 40 h.	71 x 31 x 30 h.				

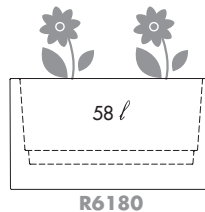

Carrello abbinabile art. F0522 (2 pz.)
Matching trolley art. F0522 (2 pieces)
Passend trolley art. F0522 (2 Stk)
Support à roulettes combinable art. F0522 (2 unités)
Set de ruedas aplicable art. F0522 (2 unidades)



GARDEN STYLE
EVOLUTION

Art. R6180
Col. P
Mix
IN OUT
Opaco - Matt

Mix&Match

Crea la soluzione che più si adatta ai tuoi spazi mescolando colori e superfici!

GARDEN STYLE
EVOLUTION



Create the solution that best suits your spaces by mixing colors and surfaces!

Créez la solution qui convient le mieux à vos espaces en mélangeant les couleurs et les surfaces!



Erstellen Sie die Lösung, die am besten zu Ihren Räumen passt, indem Sie Farben und Oberflächen mischen!



GARDEN STYLE
EVOLUTION

¡Crea la solución que mejor se adapte a tus espacios mezclando colores y superficies!

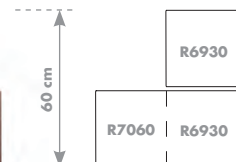
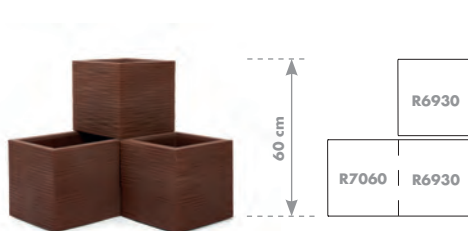
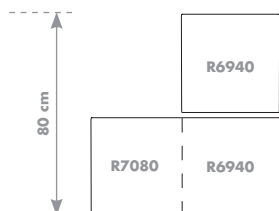

Nico's tips



Terriccio
Potting soil
Blumenerde
Terreau
Substrato

2/3

1/3

Argilla espansa
Expanded clay
Blähton
Argile expansée
Arcilla expandida

Momus

COD.



R4135	35 x 35 x 35 h.	31 x 31 x 32 h.	R3540	AV B P S
R4150	50 x 50 x 50 h.	44 x 44 x 47 h.	—	AV B P S



R4135

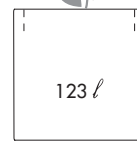

R4150

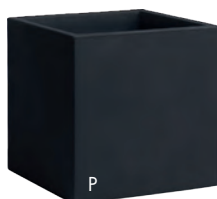
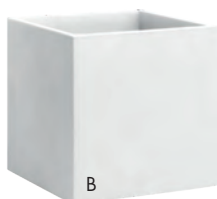



GARDEN STYLE
EVOLUTION

Art. R4150

Col. P

Philodendron



Opaco - Matt

Minos

COD.



R4425	25 x 25 x 12 h.	20,5 x 20,5 x 11 h.	AV	B	P	S
R4440	40 x 40 x 15 h.	33 x 33 x 12 h.	AV	B	P	S
R4460	60 x 60 x 22,5 h.	49,5 x 49,5 x 19,5 h.	AV	B	P	S

1
PCS

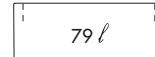
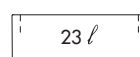
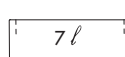

R4425

R4440

R4460

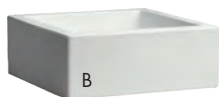

GARDEN STYLE
EVOLUTION

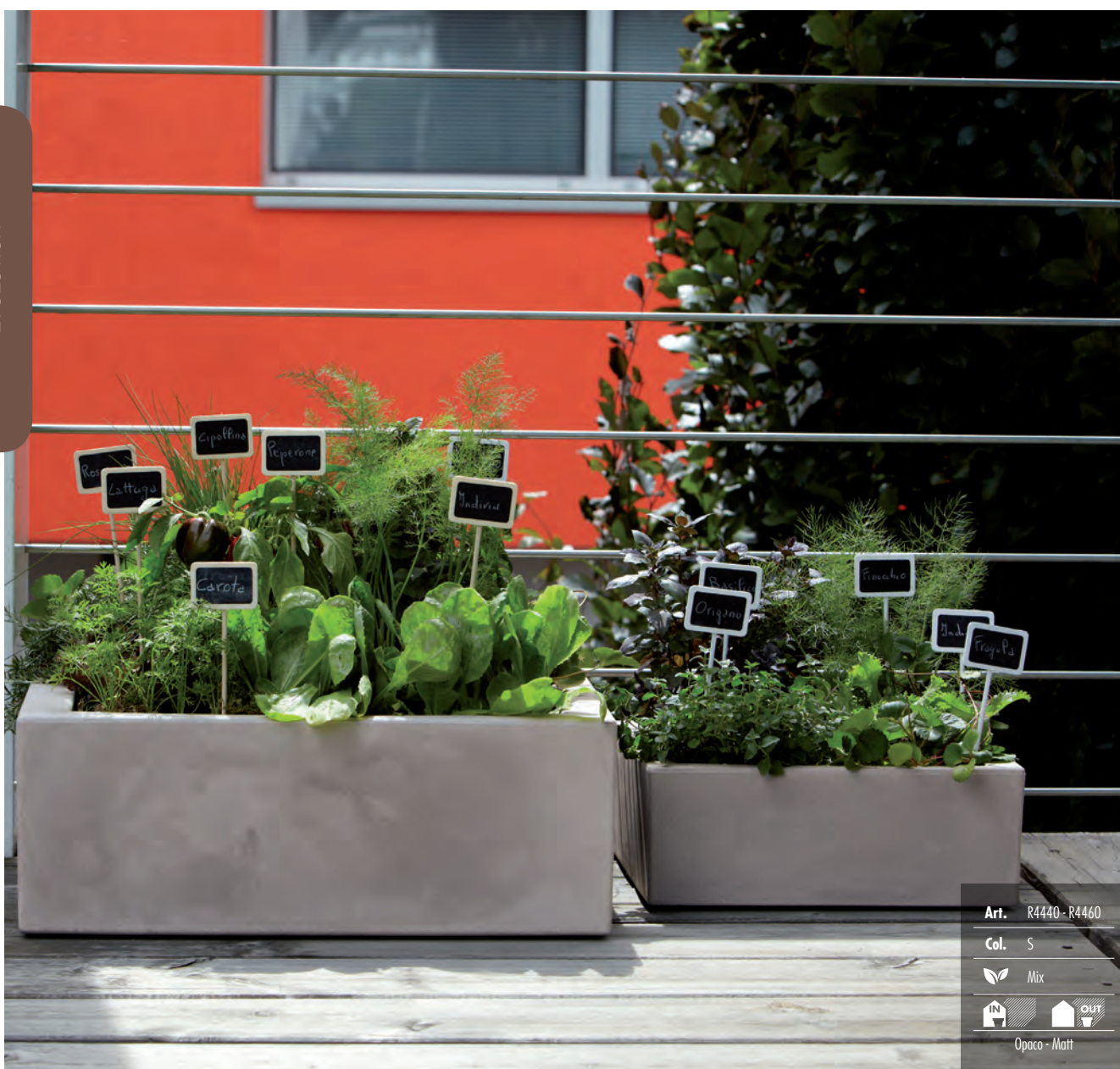

Art. R4440 - R4460

Col. S

Mix



Opaco - Matt

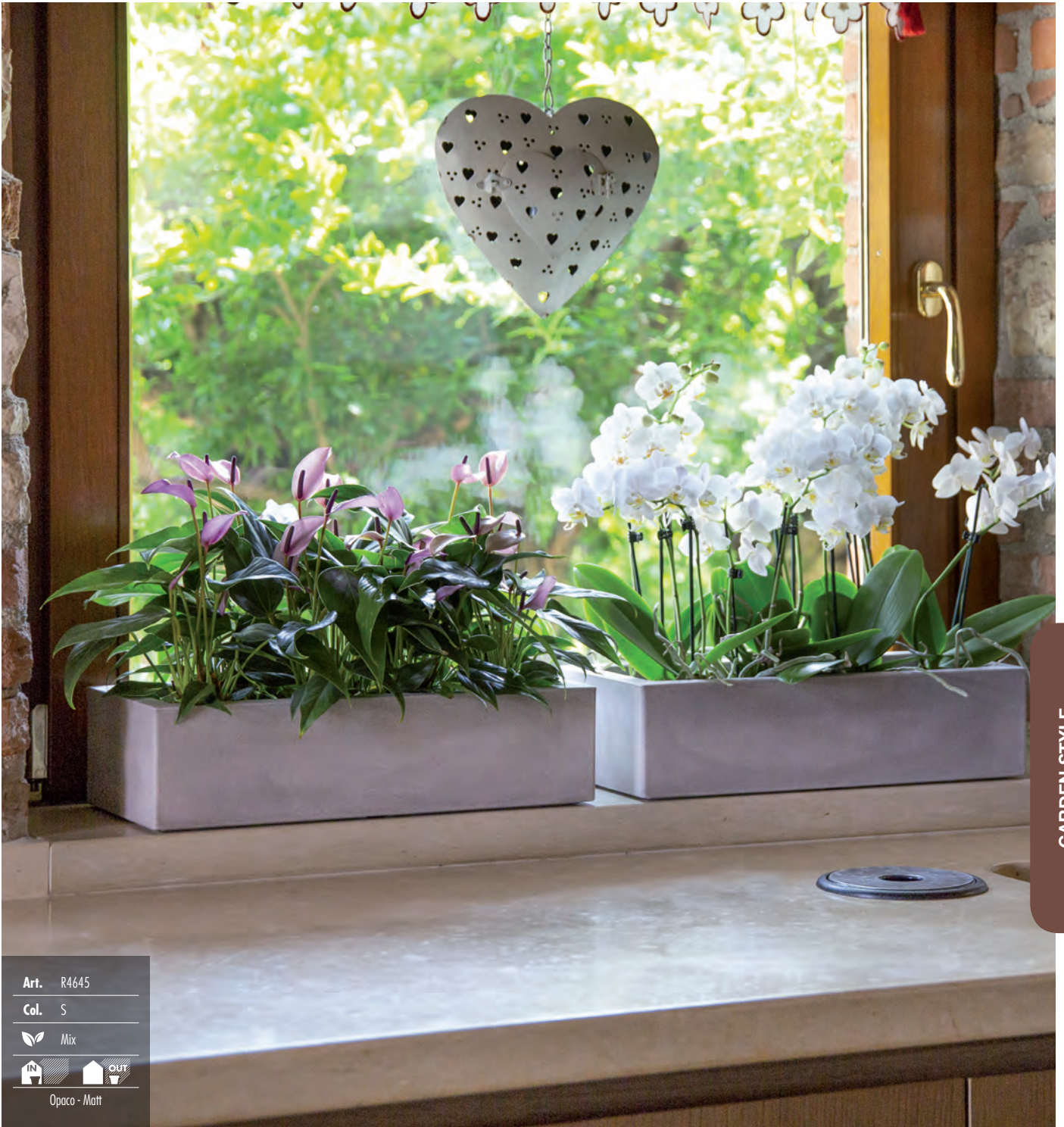

GARDEN STYLE
EVOLUTION

Art. R4645
 Col. S
 Mix
 Opaco - Matt

Minos Cassetta

COD.



R4645

45 x 20 x 12 h.

40 x 15 x 11 h.

AV B P S

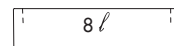

R4645



R6180

R4150

R6340

R4460

R4135

R4440

Mix&Match

GARDEN STYLE
EVOLUTION

Il tuo orto in terrazzo
Your vegetables garden on terrace
Ihrer Obstgarten auf der Terrasse
Votre potager en terrasse
Tu huerta en la terraza

Think
Creative

GARDEN STYLE
EVOLUTION

Nico's
tips





Terriccio
Potting soil
Blumenerde
Terreau
Substrato

2/3

1/3

Argilla espansa
Expanded clay
Blähton
Argile expansée
Arcilla expandida

Logos Matt

COD.					AV	B	P	S
R5330	30 x 30 x 43 h.	24 x 24 x 40 h.	—		<input checked="" type="radio"/>	<input type="radio"/>	<input type="radio"/>	<input type="radio"/>
R5340	40 x 40 x 57 h.	34 x 34 x 25 h.	R3540		<input checked="" type="radio"/>	<input type="radio"/>	<input type="radio"/>	<input type="radio"/>





GARDEN STYLE
EVOLUTION

Art. R5330 - R5340
Col. B
Mix
Opaco - Matt





Eros

COD.					AV	B	P	S
R5630	30 x 30 x 60 h.	25 x 25 x 24 h.	—	—				
R5638	38 x 38 x 80 h.	31 x 31 x 26 h.	R3540	—				

1 PCS

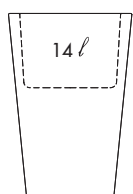

R5630

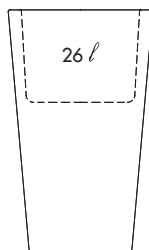

R5638



AV



B



P



S

Nico's tips



Terriccio
Potting soil
Blumenerde
Terreau
Substrato

2/3

1/3

Argilla espansa
Expanded clay
Blähton
Argile expansée
Arcilla expandida

Nico's tips

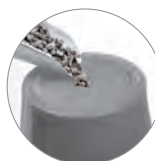

Più stabilità?
More stability?
Mehr Stabilität?
Plus de stabilité?
Más estabilidad?



PG. 194

Art. R5638

Col. B

Mix



Opaco - Matt

GARDEN STYLE
EVOLUTION

GARDEN STYLE
EVOLUTION



Art. R2640

Col. P

 Dracaena Indivisa

Opaco - Matt

Geryon

COD.



1
PCS

R2640

40 x 40 x 100 h.

36 x 36 x 46 h.

R3540

B

P

S

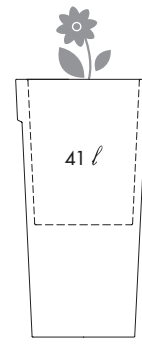

R2640



Themis Sottovaso Quadro

COD.



1
PCS

R3540

39 x 39 x 4,5 h.

35 x 35 x 4 h.

B

P

S



GARDEN STYLE
EVOLUTION

Nico's
tips



Terriccio
Potting soil
Blumenerde
Terreau
Substrato

2/3

1/3

Argilla espansa
Expanded clay
Blähton
Argile expansée
Arcilla expandida

Nico's
tips







PG. 194

Più stabilità?
More stability?
Mehr Stabilität?
Plus de stabilité?
Más estabilidad?





Art. R3099
Col. P
Phormium
Opaco - Matt

Themis Cassetta

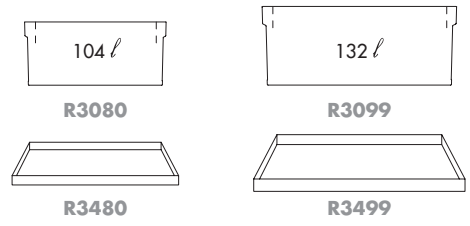
COD.	 cm.	 cm.						
 R3080	80 x 40 x 40 h.	72 x 32 x 37 h.	R3480	AV	B	I	P	S
R3099	100 x 40 x 40 h.	92 x 32 x 37 h.	R3499	AV	B	I	P	S



Themis Sottocassetta

COD.	 cm.	 cm.					
 R3480	79 x 39 x 4,5 h.	75 x 35 x 4 h.	AV	B	I	P	S
R3499	99 x 39 x 4,5 h.	95 x 35 x 4 h.	AV	B	I	P	S





Art. R3140
 Col. AV
 Shipa Tenifolia
 Opaco - Matt



GARDEN STYLE
 EVOLUTION

Themis Quadro

COD. cm. cm.

1 PCS R3140 40 x 40 x 40 h. 32 x 32 x 37 h. R3540 AV B I P S

Themis Sottovaso Quadro

COD. cm. cm.

1 PCS R3540 39 x 39 x 4,5 h. 35 x 35 x 4 h. AV B I P S

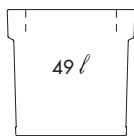

R3140

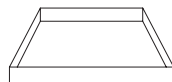

R3540



Nico's tips



Terriccio
 Potting soil
 Blumenerde
 Terreau
 Substrato

2/3

1/3

Argilla espansa
 Expanded clay
 Blähton
 Argile expansée
 Arcilla expandida



Art. R3240 - R3640





Col. AV

 Croton

  OUT

Opaco - Matt

Themis Angolare

COD.	 cm.	 cm.					
 R3240	40 x 40 x 40 h.	32 x 32 x 37 h.	R3640	AV	I	P	S

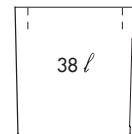

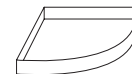

R3240



R3640

Themis Sottovaso Angolare

COD.	 cm.	 cm.				
 R3640	39 x 39 x 4,5 h.	35 x 35 x 4 h.	AV	I	P	S





Art. R3340 - R3740
 Col. P
 Yucca
 IN OUT
 Opaco - Matt

GARDEN STYLE
EVOLUTION

Themis Parete

COD. cm. cm.

1 R3340 40 x 28 x 40 h. 32 x 20 x 37 h. R3740 **AV I P S**
 PCS

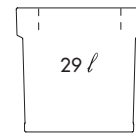

R3340

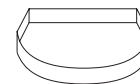

R3740

Themis Sottovaso Parete

COD. cm. cm.

1 R3740 39 x 27 x 4,5 h. 35 x 23 x 4 h. **AV I P S**
 PCS





Think
Creative



GARDEN STYLE
EVOLUTION



GARDEN STYLE
EVOLUTION



Art. R0699 - R0840

Col. I

 Nerium Oleander

Opaco - Matt

Millerighe Cassetta

COD.



R0660 60 x 29 x 26 h. 52,5 x 22 x 23 h. R3460

R0680 80 x 39 x 34 h. 72 x 31 x 31 h. R3480

R0699 100 x 39 x 34 h. 92 x 31 x 31 h. R3499



1
PCS

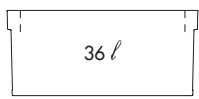

36 l

R0660



R3460

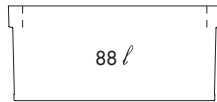

88 l

R0680

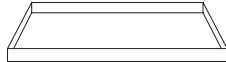

R3480

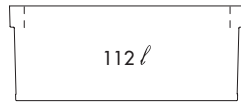

112 l

R0699

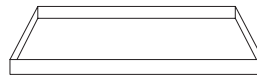

R3499

Themis Sottocassetta

COD.



R3460 60,5 x 30,5 x 4 h. 56,5 x 26,5 x 3,5 h.

R3480 79 x 39 x 4,5 h. 75 x 35 x 4 h.

R3499 99 x 39 x 4,5 h. 95 x 35 x 4 h.

1
PCS

Millerighe Quadro

COD.



R0840 39 x 39 x 34 h. 31 x 31 x 31 h. R3540

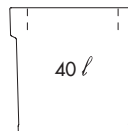

R0840

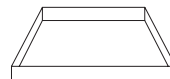

R3540



1
PCS

Themis Sottovaso Quadro

COD.



R3540 39 x 39 x 4,5 h. 35 x 35 x 4 h.

1
PCS

ACCESSORI
ACCESSORIES
ZUBEHÖRE
ACCESSOIRES
ACCESORIOS

Etichetta



COD.		A x B cm	
50 PCS	912	verticale - vertical aufrechte	5,3 x 4 x 11 h. G
	925	verticale - vertical aufrechte	6,5 x 4,5 x 24 h. G
10 PCS	930	verticale - vertical aufrechte	10 x 7 x 24 h. G
	935	inclinata - tilted geneigt - incliné	10 x 7 x 35 h. G
10 PCS	945	inclinata - tilted geneigt - incliné	16 x 10 x 43 h. G

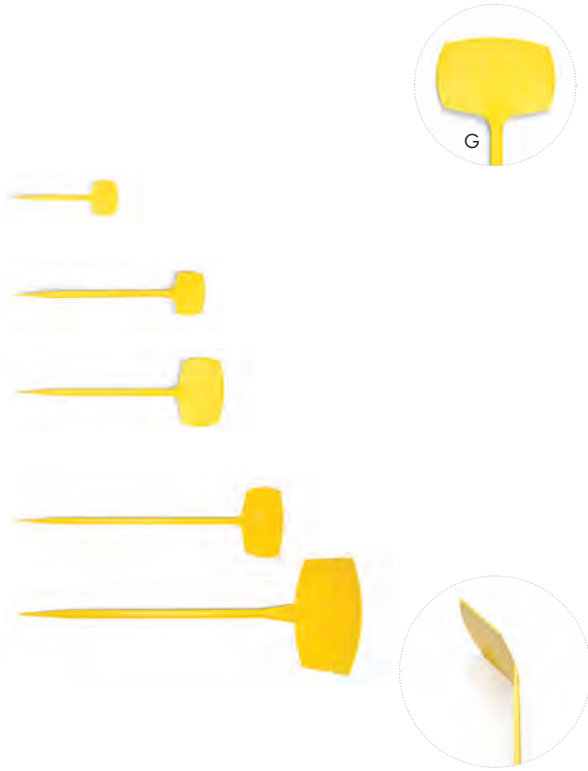

Carrello Rotondo

Metallo verniciato a polveri - Powder coated metal - Pulverbeschichtetes Metall
Fer revêtu époxy - Hierro con recubrimiento en polvo

COD.	A x H cm	cm.	
3 PCS	F0425	27 x 6,5 h.	25 Z
	F0430	32 x 6,5 h.	30 Z
	F0435	37 x 7 h.	35 Z
	F0440	42 x 7 h.	40 Z
	F0450	52 x 7,5 h.	50 Z

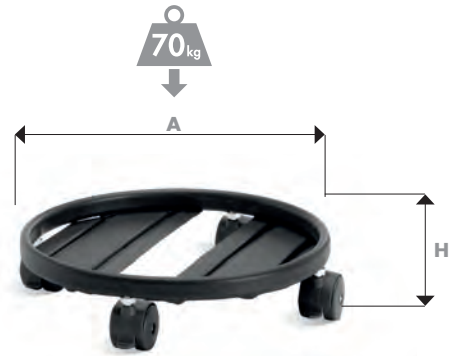

Carrello Quadrato

Metallo verniciato a polveri - Powder coated metal - Pulverbeschichtetes Metall
Fer revêtu époxy - Hierro con recubrimiento en polvo

COD.	A x B x H cm	cm.	
3 PCS	F0522	27 x 27 x 6,5 h.	23 x 23 Z
	F0529	33 x 33 x 6,5 h.	29 x 29 Z
	F0533	37 x 37 x 6,5 h.	33 x 33 Z

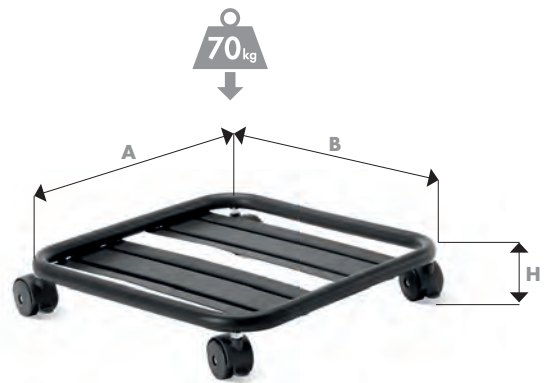

Carrello Rettangolare

Metallo verniciato a polveri - Powder coated metal - Pulverbeschichtetes Metall
Fer revêtu époxy - Hierro con recubrimiento en polvo

COD.	A x B x H cm	cm.	
3 PCS	F0660	60 x 30 x 7,5 h.	55,5 x 25,5 Z
	F0680	76 x 36 x 7,5 h.	71 x 31,5 Z
	F06100	95 x 41 x 7,5 h.	90,5 x 36,5 Z

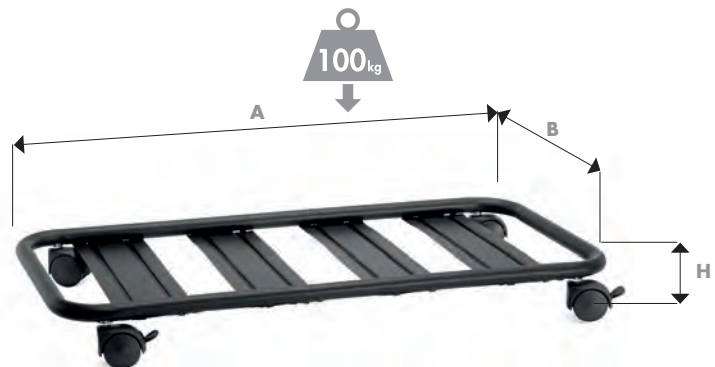

GARDEN STYLE
ACCESSORI

Garden Shop

PRESENTATION



Nico's
tips



Think Creative

AUMENTA LE VENDITE
CON GLI EXPO VISUAL NICOLI.

INCREASE SALES WITH
NICOLI'S VISUALS EXPO.



DISPLAY EXPO ARKÈ
VERSIONE SOLO VASI - ONLY POTS

39D01 P T B GRG CP SA

DISPLAY NON INCLUSO - DISPLAY NOT INCLUDED



DISPLAY EXPO ARKÈ
VERSIONE VASI E SOTTOVASI - POTS & SAUCERS

39D02 P T B GRG CP SA

DISPLAY NON INCLUSO - DISPLAY NOT INCLUDED

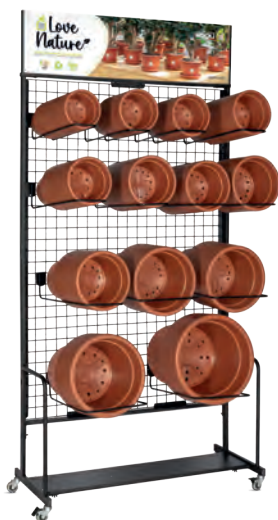

DISPLAY EXPO PREMIUM
VERSIONE SOLO VASI - ONLY POTS

24D01 C B P T

DISPLAY NON INCLUSO - DISPLAY NOT INCLUDED



DISPLAY EXPO PREMIUM
VERSIONE VASI E SOTTOVASI - POTS & SAUCERS

24D02 C B P T

DISPLAY NON INCLUSO - DISPLAY NOT INCLUDED



DISPLAY EXPO DOMUS
VERSIONE SOLO SOTTOVASI - ONLY SAUCERS

43D01 C V P

DISPLAY NON INCLUSO - DISPLAY NOT INCLUDED

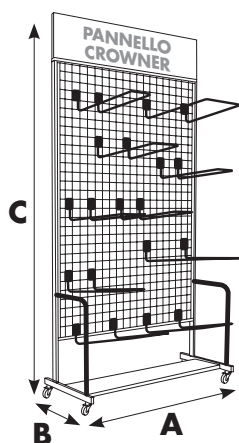

EXPO DISPLAY

COD. A x B x C
cm

8901N 104 x 46 x 210 h.

Metallo verniciato a polveri
Powder coated metal
Pulverbeschichtetes
Metall Fer revêtu epoxy
Hierro con recubrimiento en polvo

**PANNELLO
CROWNER**



Pannello bifacciale / Double-sided crowner

Garden Shop

PRESENTATION



BOX CASSETTA DOMUS COMPLETA

55MM1C	C	V	GRG	P	T	VRO
55M40	C	V	GRG	P	T	VRO
55M50	C	V	GRG	P	T	VRO
55M60	C	V	GRG	P	T	VRO



BOX CASSETTA PRIMAVERA

25MM2	C	P	T
25M40	C	P	T
25M50	C	P	T
25M60	C	P	T



BOX BALCONIERA DOMUS FISSA

81M40	Z
81M50	Z
81M60	Z



BOX KIT PRIMAVERA

28SM40	C	P	T
28SM50	C	P	T
28SM60	C	P	T



MATERIALE ESPOSITIVO

VISUAL MERCHANDISING - MARCHANSIDAGE VISUEL
MERCHANDISING VISUAL

Nico's
tips



Think Creative

AUMENTA LE VENDITE
CON GLI EXPO VISUAL NICOLI.

INCREASE SALES WITH
NICOLI'S VISUALS EXPO.

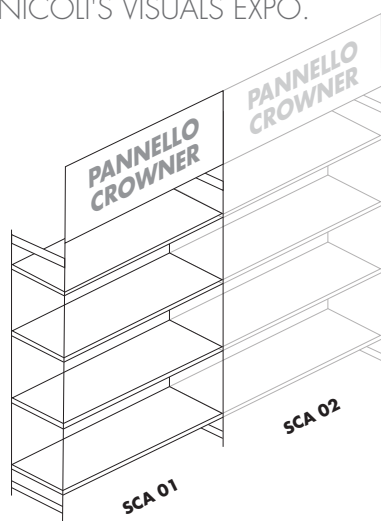

Contattate il vostro referente aziendale per le
condizioni di fornitura

Contact your company representative for supply
conditions

Kontaktieren Sie Ihren Firmenvertreter für die
Lieferbedingungen

Contactez votre correspondant de la société pour
connaître les conditions d'approvisionnement

Pida información a su representante para el
suministro

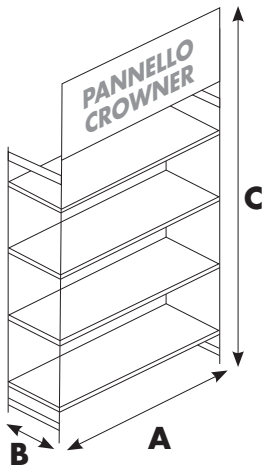

SCAFFALE - SCA 01

COD.	A x B x C cm
SCA01	120 x 60 x 250 h.

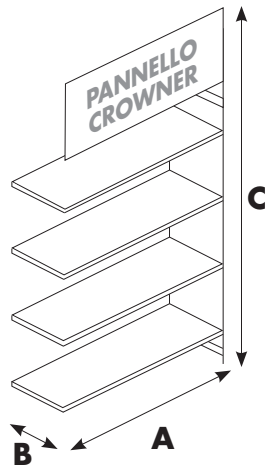

SCAFFALE - SCA 02

ABBINABILE A SCA01 - MATCHING WITH SCA01 - PASSEND ZU SCA01 -
COMBINABLE AVEC SCA01 - SE COMBINA CON SCA01

COD.	A x B x C cm
SCA02	120 x 60 x 250 h.

Think
Creative

SCEGLI IL PANNELLO PIÙ ADATTO AL TUO SPAZIO ESPOSITIVO.
CHOOSE THE PANEL BEST SUITED TO YOUR EXHIBITION SPACE.

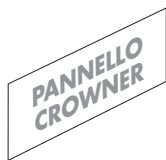

PANNELLO - CROWNER COD. PAN 01



PANNELLO - CROWNER COD. PAN 02



PANNELLO - CROWNER COD. PAN 03



PANNELLO - CROWNER COD. PAN 04



Pannelli bifacciali / Double-sided crowners

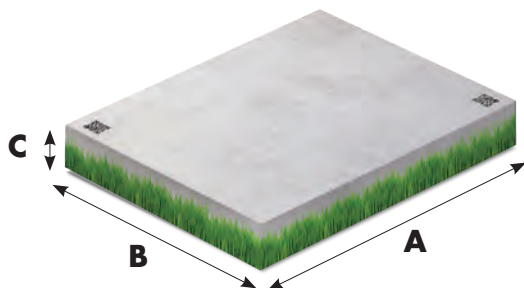

COPRI PALLET

COD.	A x B x C cm
COPRI	120 x 80 x 13 h.

Stampaggio ad iniezione
Injection moulding

INJECTION
moulding



POLIPROPILENE
POLYPROPYLENE

COME SI FA?

How is it made?

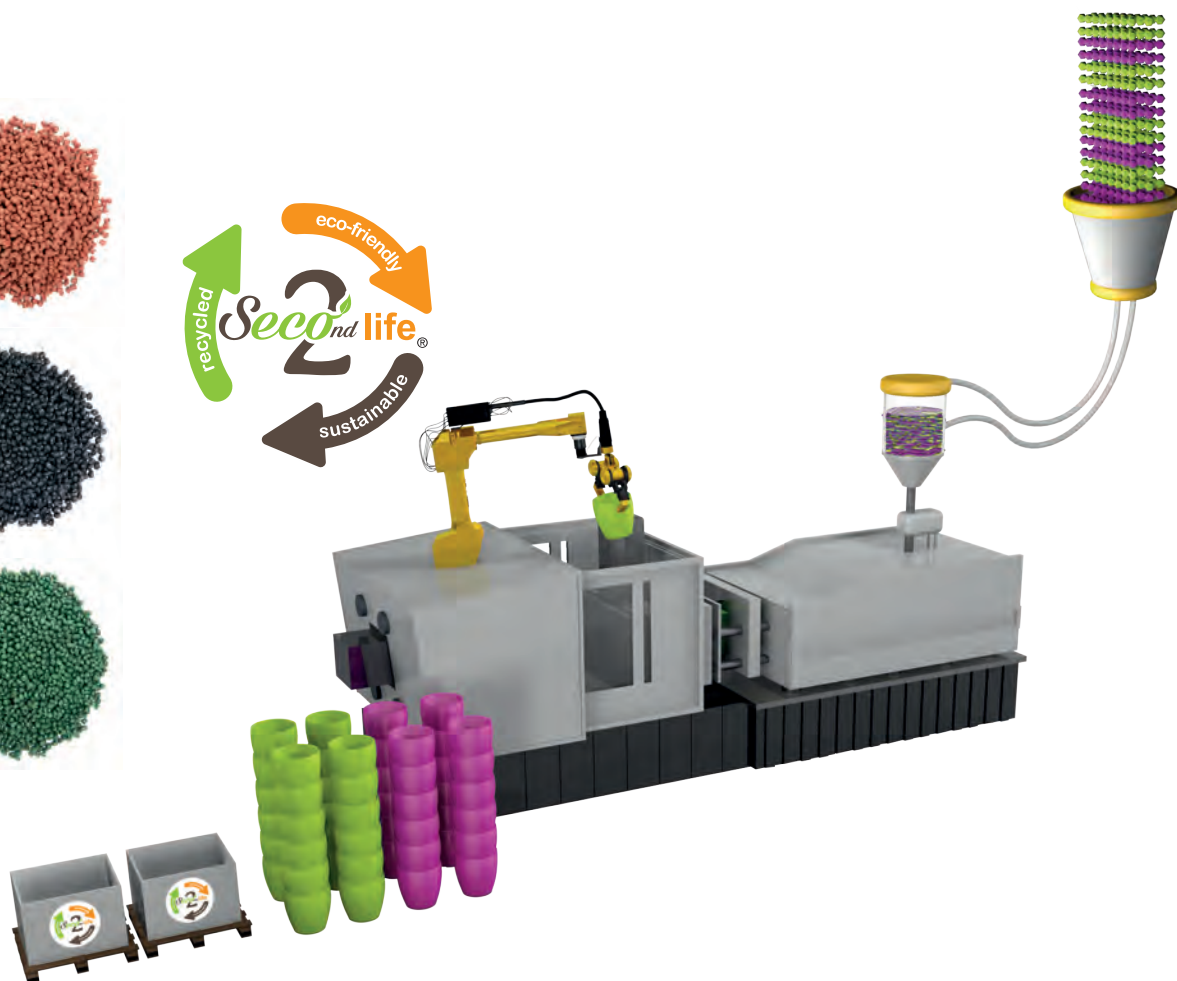

100%

**MATERIALI ATOSSICI E RICICLABILI
NON TOXIC AND RECYCLABLE MATERIALS**

SOSTENIBILE SUSTAINABLE

**ENERGIA ELETTRICA DA FONTI RINNOVABILI
ELECTRICITY FROM RENEWABLE SOURCES**

0%

**EMISSIONI DI CO₂
CO₂ EMISSIONS**

Stampaggio rotazionale
Rotational moulding

ROTO
moulding



L.L.D.P.E.

POLIETILENE
RICICLABILE

RECYCLABLE
POLYETHYLENE

COME SI FA?

How is it made?

Ciclo completo di produzione 60 min. per ogni prodotto
Complete production cycle 60min for each product

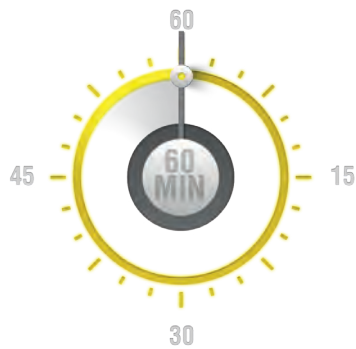

- 1 RIEMPIMENTO STAMPI
MOULDS FILLING
- 2 FORNO
OVEN
- 3 STAZIONE DI RAFFREDDAMENTO
COOLING STATION
- 4 ESTRAZIONE DEL PRODOTTO
PRODUCT EXTRACTION
- 5 FINITURA A MANO
HAND FINISHING

INFO & VISUAL
MERCHANDISING



COME SI USA

How to use it? Wie nutzt es man?
Comment l'utilise-t-on? Como se usa?



VIDEO



1

modelli con parete singola
single wall models
einzelwand Modellen
modèles à simple paroi
modelos de pared simple



2

modelli con parete doppia
double wall models
doppelwand Modellen
modèles à double paroi
modelos de pared doble



INTERNO - INDOOR - DRINNEN - POUR INTÉRIEUR - INTERIOR

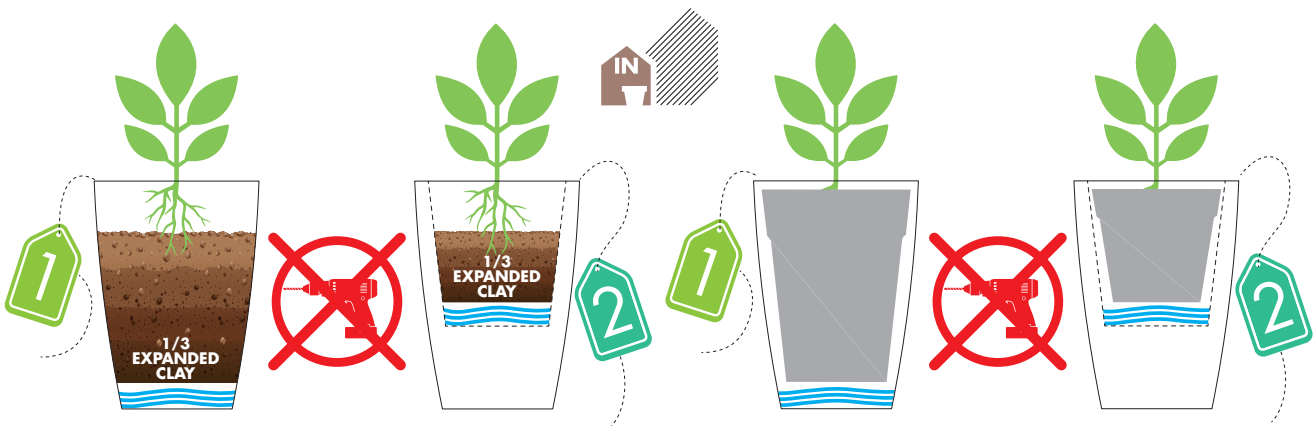

COME VASO
as a flowerpot - als Topf
comme pot - como maceta

COME COPRIVASO
as a cachepot - als Übertopf
comme cache-pot - como cubremaceta

ESTERNO - OUTDOOR - DRAUSSEN - POUR L'EXTÉRIEUR - EXTERIOR

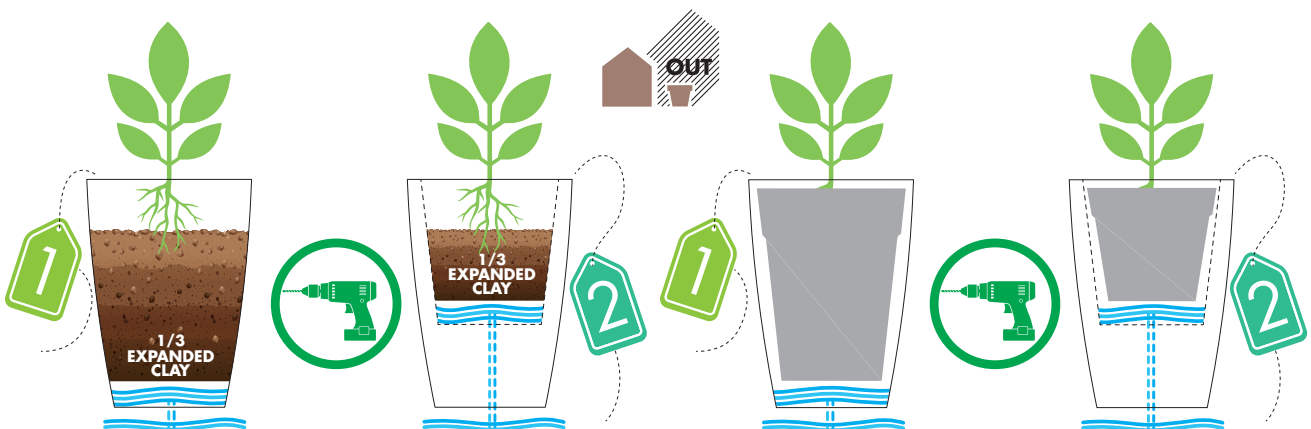

COME VASO
as a flowerpot - als Topf
comme pot - como maceta

COME COPRIVASO
as a cachepot - als Übertopf
comme cache-pot - como cubremaceta

PIÙ STABILITÀ

More stability? Mehr Stabilität?
Plus de stabilité? Más estabilidad?



TALOS



EROS



GERYON



VIDEO



RIEMPIMENTO CON GHIAINO

filling with gravel

Befüllung mit Kies

remplissage avec gravier

rellenar con gravilla

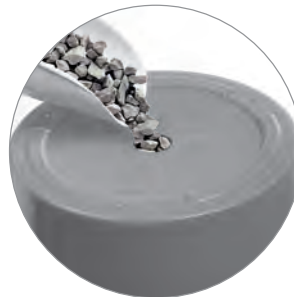
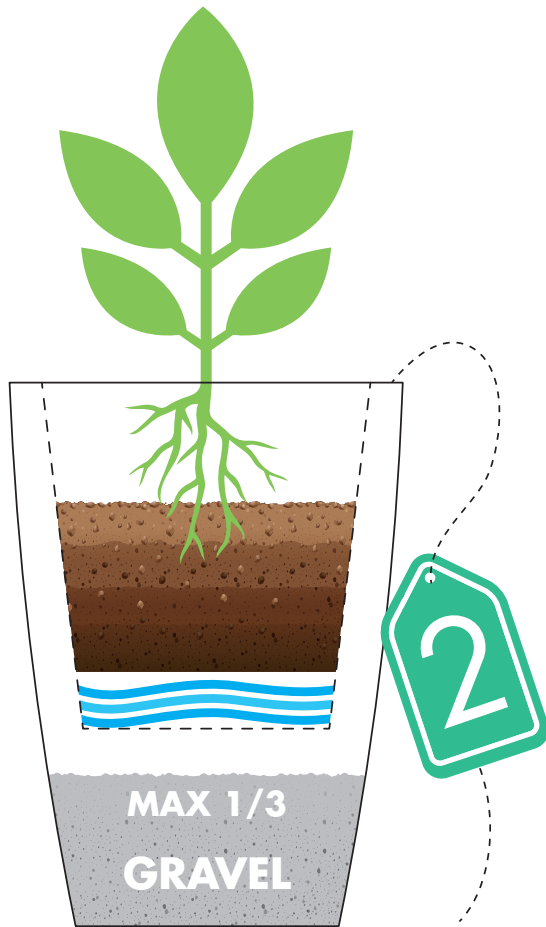

NON RIEMPIRE CON ACQUA
DO NOT FILL WITH WATER
NICHT MIT WASSER AUSFÜLLEN
NE PAS REMPLIR D'EAU
NO RELLENAR CON AGUA

COME RINVASARE LE PIANTE

How to repot plants - Wie man Pflanzen umtopft
 Comment repoter les plantes - Cómo trasplantar plantas

Nico's
tips



1



Riempite 1/3 del vaso con argilla espansa.
 Fill 1/3 of the pot with expanded clay
 Füllen Sie 1/3 des Topfes mit Blähton.
 Remplir 1/3 du pot avec de l'argile expansée.
 Llenar 1/3 de la maceta con arcilla expandida.

2

Aggiungere un pò di terriccio e adagiare la pianta.
 Add a little soil and lay the plant down.
 Fügen Sie ein wenig Erde hinzu und stellen Sie die Pflanze hin.
 Ajouter un peu de terre et déposer la plante.
 Agregue un poco de tierra y coloque la planta.



3



Riempire con altro terriccio e compattare bene.
 Fill with more potting soil and compact well.
 Mit mehr Erde auffüllen und gut verdichten.
 Remplissez avec plus de terre et compactez bien.
 Rellenar con más tierra y compactar bien.

4

Annaffiate
 Water it
 Bewässern
 Arroser
 Regar



2/3

Terriccio - Potting soil
 Blumenerde - Terreau
 Substrato

1/3





















Argilla espansa - Expanded clay
 Blähton - Argile expansée
 Arcilla expandida

Guida sottovasi



Saucer guide - Untersetzenanleitung

Guide aux soucoupes - Guía de platillos

ATLAS SOTTOVASO







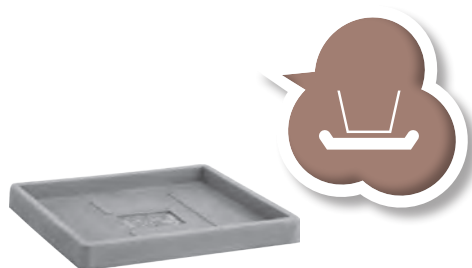



COD.	 cm.	 cm.	AV	B	CT	I	P	S		
R1626	26 x 3,5 h.	22 x 3 h.	AV	B	CT	I	P	S		
R1630	30 x 3,7 h.	25,5 x 3,2 h.	AV	B	CT	I	P	S		
R1632	32,5 x 3,9 h.	27 x 3,4 h.	AV	B	CT		P	S		
R1636	36,5 x 4,2 h.	30 x 3,7 h.	AV	B	CT	I	P	S		
R1642	42,5 x 5 h.	36 x 4,5 h.	AV	B	CT	I	P	S		
R1648	48,5 x 5,3 h.	42 x 4,8 h.	AV	B	CT		P	S		
R1652	52,5 x 5,3 h.	46 x 4,8 h.	AV	B			P	S		
R1658	58,5 x 5,8 h.	51 x 5,3 h.	AV	B		I	P	S		

THEMIS SOTTOVASO QUADRO





COD.	 cm.	 cm.	AV	B	I	P	S
R3540	39 x 39 x 4,5 h.	35 x 35 x 4 h.	AV	B	I	P	S



ABBINABILI A - MATCHING WITH - PASSEND FÜR - COMBINABLE AVEC - SE COMBINA CON

											
	ZEUS	TALOS 33-43	TYLUS 30-40	THETIS 30-40-50-60	HERA 30-40-50-60	RHEA - HERMES 30-40	ECHO	CHIRON 50-60	DOPPIO BORDO LISCIO 35-45-55-75	DOPPIO BORDO FESTONATO 30-40-50-60	ARES 20-30-40
R1626	R7130	-	R4330 R6830	-	-	-	-	-	R0135	R0230	-
R1630	-	R2733 R0533	-	R0930	R3830 R0730	R7330 R7230	-	-	-	R0240	R3930
R1632	R7140	-	-	-	-	-	-	R6050	-	-	-
R1636	-	R2743	R4340	-	-	R7340 R7240	-	R6060	R0145	R0250	R3940
R1642	R7150	-	-	R4240 R0940	R3840 R0740	-	R5535	-	R0155	R0260	-
R1648	R7160	-	-	R4250	R3850 R0750	-	-	-	-	-	-
R1652	-	-	-	-	-	-	-	-	-	-	-
R1658	-	-	-	R4260	R3860	-	-	-	R0175	-	-

ABBINABILI A - MATCHING WITH - PASSEND FÜR - COMBINABLE AVEC - SE COMBINA CON

					
	THEMIS QUADRO	MILLERIGHE QUADRO	MOMUS	GERYON	EROS
R3540	R3140	R0840	R4135	R2640	R5638

we look to the fu ture

na

Le foto illustrative e le informazioni contenute in questo catalogo sono puramente indicative. I prodotti, le relative caratteristiche tecniche e gli imballaggi possono essere modificati anche senza preavviso a discrezione dell'azienda in qualsiasi momento.

The photos and illustrations in this catalogue are purely indicative. Products, respective technical characteristics, and packages can be modified at the company's own discretion without advance notice in any moment.

Die Fotos und die technische Informationen in diesem Katalog sind nicht verpflichtend und können ohne Vorwarnung verbessert oder geändert werden.

Les photos et les informations techniques dans ce catalogue ne sont pas contraignants et peuvent être améliorées et modifiées par Nicoli srl sans préavis.

Las fotografías e ilustraciones de este catálogo son meramente indicativas. Los productos, sus características técnicas y los embalajes pueden ser modificados a discreción de la empresa sin previo aviso en cualquier momento.

THANKS TO

¡ FIORI ☉ MAURI

CREDITS

Project: Tucano Group srl
Photo: Tucano Group srl



MADE IN ITALY



NICOLI srl
Via del Lavoro, 10
36070 Brogliano (VI) - Italia

Tel. +39 0445 947344
Fax +39 0445 947239

info@nicoli.com
www.nicoli.com



CATALOGO GARDEN
GARDEN CATALOGUE



LISTINO
PRICE LIST